

The Product Safety Engineering Newsletter

What's Inside

President's Message	1
Officers of the IEEE PSES	2
Chapter Activities	4
Insulation Coordination for High Frequencies	6
Touch Current Measurement Comparison	24
News and Notes	23
Editorial	5
Institutional Listings	43

Vol. 4, No. 3 September 2008

President's Message

As we finish up the third quarter's newsletter, just a little late this time (sigh), we are just days away from our symposium in Austin Texas. I hope to see all of you there. All the plans are in place with no ill effects to the symposium from Ike. We expect the symposium to be the best one to date. We have people working on 2009 symposium and the Planning has already started on the 2010 symposium.

It is going to be a busy three months for those on the Board of Directors of the IEEE PSES. We once again have to go through the Society Review Committee's (SRC) process, as we are a provisional society. We have already received the request for our current status. They have sent us the forms to fill out once again. We are required to reply by December and be prepared to discuss in person at their meeting in February. My intent is to make sure we do a super job this time to convince them we should be removed from provisional list.

Part of what will need to happen is we need more members to step up and take an active role in the

society. There are lots of options, start a local chapter, join a TAC, help the symposium committee or one of the many other committees the BoD has. One place we really could use help is in helping promote

the society to increase awareness and membership. So if you have a sales or marketing background, we could really use your help.

It is that time of year that you must renew your IEEE membership. Please remember to renew early and include the Safety Society on your renewal. Like the other societies, we have a large loss of members every year. The difference between us and the other societies is we gain enough new members to make up for the loss and then some. If we could prevent the normal loss a society has for a couple years, it would significantly boost our stability. So please renew ASAP. I would

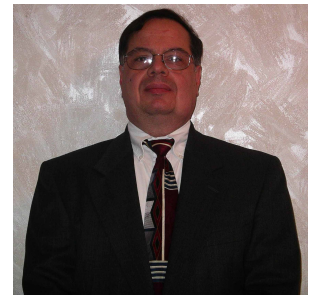

**The
Product
Safety
Engineering
Newsletter**

The Product Safety Engineering Newsletter is published by the IEEE Product Safety Engineering Society. No part of this newsletter may be reproduced without written permission of the authors. All rights to the article remain with the authors.

Opinions expressed in this newsletter are those of the authors and do not necessarily represent the opinions of the Society or any of its members. Indeed, there may be and often are substantial disagreements with some of the opinions expressed by the authors.

Copyright 2008 IEEE Product Safety Engineering Society.

Newsletter Committee

Editor:

Gary Weidner 1-563-557-0717 (v) 1-563.557.0725 (fax) gweidner@ieee.org

Co-Editors:

Michael S. Morse Ph. D. mmorse@sandiego.edu
 Richard Nute richn@ieee.org
 Nosh Medora nmedora@exponent.com
 Lal Bahra Lal_Bahra@Dell.com
 Lingfeng Chen gzclf2-ieee@yahoo.com.cn

News & Notes:

Your name here

Chapter Activities:

Stefan Mozar s.mozar@ieee.org

Page Layout:

Jim Bacher 1-937.865-2020(v) 1-937.865.2048 (fax) j.bacher@ieee.org

IEEE PSES Officers

Executive Committee	Name	Term
President	Jim Bacher	(08-09)
Past President	Henry Benitez	(08-09)
President Elect	TBD	
Secretary	Daniece Carpenter	(07-08)
Treasurer	Murlin Marks	(07-08)
Vice President - Communications	Dan Roman	(07-08)
Vice President - Member Services	Ken Thomas	(07-08)
Vice President - Technical Activities	Jack Burns	(07-08)
Vice President - Conferences	Richard Georgerian	(07-08)

Directors At Large

Term Expires 12/08	Term Expires 12/09	Term Expires 12/10	Ex Officio (without vote)
Jack Burns	Daniece Carpenter	Jim Bacher	Chapter Chairs
Murlin Marks	Richard Georgerian	Mark Montrose	Standing Committee Chairs
Richard Pescatore	Elya Joffe	Doug Nix	IEEE HQ
Ken Thomas	Daniel Nachtigall	Peter Tarver	IEEE TAB Division VI Director
			Gold Member

IEEE PSES Web Sites

- <http://www.ieee-pses.org/>
- <http://www.ieee-pses.org/symposium/>
- <http://www.ieee-communities.org/emc-pstc>
- <http://www.ieee-pses.org/emc-pstc.html>
- <http://www.ieee-pses.org/newsletters.html>
- <http://www.ieee-pses.org/pses.html>



love to be able to go into the SRC meeting showing them that all of our members renewed. It would be mind-blowing for the SRC.

I look forward to seeing all of you in Austin at the symposium.

Jim

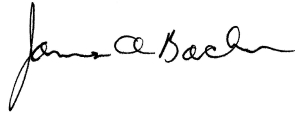

James A. Bacher
President IEEE PSES

Seeking Nominations for IEEE Medals and Recognitions

The IEEE Awards Board is seeking nominations for IEEE Medals and Recognitions and encourages the use of its online Potential Nominee Form. This form allows a preliminary review of a nominee by the selection committee and an opportunity to obtain feedback prior to submitting an official nomination form. The Potential Nominee Form is available on the IEEE Awards Web Page at:

<http://www.ieee.org/portal/pages/about/awards/noms/potnomform.html>

The deadline for submission of an official nomination form for any of the IEEE Medals and Recognitions is 1 July 2008. For questions concerning the Potential Nominee Form, please contact awards@ieee.org.

Chapter Safety Probes

To see current chapter information please go to the
chapter page at:

<http://www.ieee-pses.org/Chapters/index.html>

People Looking To Start Chapters

Denver Colorado

Richard Georgerian
voice: (303) 833-2327
e-mail: richardg@ieee.org

Toronto Ontario

Doug Nix
dnix@ieee.org
voice: (519) 729-5704
FaX: (519) 653-1318

North Carolina

Warren Fields (ncps@bellsouth.net).

Dallas Texas

Mike Cantwell, PE
Sr. Account Representative
Intertek ETL SEMKO
420 N. Dorothy Dr.
Richardson, TX 75081
Tel: 972-238-5591 x107
Fax: 972-238-1860
e-mail: mike.cantwell@intertek.com
or
Bill Paschetag b.paschetag@verizon.net

Southern California

Charles Bayhi (bayhi@cpsm-corp.com).

Do not forget about our job listings on our
website.

EDITORIAL

Ready...Shoot...Aim

It's certainly wise to do some planning before undertaking a complex activity—sort of like taking aim before you shoot. In the recent changes (with more likely to come) to the U.S. the product safety system, there appears to be somewhat of a trend toward more shooting with less aiming.

Maybe another old expression, “Too many cooks spoil the broth,” applies as well. The uproar of this summer over matters such as toy safety has been partly pushed to the background by the current economic meltdown, but you can bet it will resurface. The summertime flap resulted in Congress deciding it had to “do something,” and accordingly legislation was passed revamping the Consumer Product Safety Commission and requiring mandatory third-party testing for several types of products, mainly those related to children. (Similar events transpired in Canada.)

When it comes to tinkering with a country's product safety system, the wisdom of gathering input from all interested parties is apparent. The problem is that there seems to be no master plan and no guiding organization. The American National Standards Institute (ANSI) strives mightily to be the guiding organization, but in the sort of chaos that reigned this summer, ANSI seemed to be just one of many voices.

The public blithely assumes that the federal government is supposed to make sure that anything offered for sale is safe, lots of niche organizations are serving up their own ideas of how product safety should work, and meanwhile it seems that few are aware, for example of how the U.S. and EU product safety systems work.

As product safety professionals know, compliance is generally voluntary in the U.S., but product safety certification must be done by a recognized third-party testing laboratory. On the other hand, compliance is generally mandatory within the EU market, but most certifications are via manufacturers' self-declarations instead of from third parties. If some critics of the present system (such as Consumers Union) have their way, we will leapfrog the EU and go to mandatory third-party testing of most products.

Starting with the U.S. congress, some coherent thought needs to be given to what the ground rules and basic philosophy will be!

—Gary Weidner

Insulation Coordination for High Frequencies

by Lal Bahra

This article explains the effect of high frequencies on clearances, creepage distances, and solid insulation, and points out some unresolved issues. The high frequency requirements apply to basic, supplementary, and reinforced insulation. (High frequencies are usually considered to be those greater than 30 kHz.)

Background

Not all of the applications shown in Table 1 require safety insulations, and high frequency requirements may not apply, but they do apply for example, to switch mode power supplies (SMPSs), which are used extensively in electronic products.

Table 1. Some example applications of high frequency voltages

Frequency MHz	Wave length m	Tolerance MHz	Application
0.05 to 1	-	-	Switch mode power supplies
0.03 to 0.15	-	-	Computer displays
869	-	-	Cellular base station transmitters
13.56 to 27.12	22.1 to 11	0.07 to 0.163	High frequency heating
915 to 2450	0.33 to 0.12	13 to 50	Microwave heating

The IT industry has led in trends toward smaller and smaller equipment sizes, which are now preferred by consumers, and manufacturers are trying to miniaturize their products. In order to accomplish that, power supplies have to be made smaller and smaller.

The transformer in an SMPS operates at a high fundamental frequency, so it develops a very high electrical stress in the insulation due to higher temperature, humidity, possible partial discharge effect, and high frequency which lowers the electric field strength of the material. (The waveforms in an SMPS are non-linear and contain plenty of harmonics in addition to the fundamental high frequency; the harmonics have low amplitude and are ignored in the requirements described in this article).

Consequently, there is a constant need for development of good materials offering high electric field strength. For example, Kapton, a particular form of polyimide, has an electric field strength of 303 kV/mm compared to only 50 kV/mm for polyethylene (the voltage values are rms), allowing a smaller thickness of Kapton compared to polyethylene for the same electric strength test voltage. Because the higher electric field strength results in more desirable insulating materials (a smaller thickness of material passes the required electric strength test), this helps to make the products smaller.

Unfortunately, better insulators for electricity are also better insulators against propagation of heat. At higher frequencies, dielectric losses are higher, resulting in more heat generation, and use of good

insulating materials does not help in conducting away the heat that is generated unless other means such as fans or liquid cooling systems are used.

At higher frequencies, the partial discharge effect is also increased. As a result, insulation dimensions for higher frequencies have to be increased compared to insulation dimensions for power frequencies. Manufacturers need to develop materials which when molded or rolled into thin sheets do not have any voids or gaps (which are the sites for partial discharge) and thus avoid further increased dimensioning. This article does not address partial discharges.

For frequencies above 30 kHz, IEC 60950-1¹ says, “The insulation requirements given in 2.10 are for frequencies up to 30 kHz. It is permitted to use the same requirements for insulation operating at frequencies over 30 kHz until additional data is available.”

Now the additional data is available. The IEC TR 60664-4 has been published as an IEC standard now known as IEC 60664-4: 2005, *Considerations of high frequency voltage stress*.² This is a basic safety publication and all IEC technical committees must follow this standard; TCs for vertical standards are working to adopt these requirements.

Clearances

Breakdown of a clearance is a very fast phenomenon; it can occur in less than a microsecond. Therefore, at power frequencies, the ac voltage is a constant voltage as far as breakdown is concerned. At higher frequencies that may not be true. The breakdown may not be able to hold or initiate because the voltage may come down to a low value very fast or might even reverse. This implies that the high frequency breakdown voltage may be higher than the power frequency breakdown.

But at these higher frequencies when the ionization of air starts, the ions take some time to travel from one conductive part to the other. If the polarity of the voltage reverses before all the ions have reached the other conductive part, then the field becomes distorted and the breakdown voltage is actually reduced before it goes up. The data in figures A.1 and A.2 of IEC 60664-4 supports this and shows that the breakdown voltage for the same clearance decreases starting from power frequencies to about 2.5 MHz, and then the breakdown voltage starts increasing as the frequency goes up.

The data in IEC 60664-4 shows that a 2 mm distance will break down at about 8 kV peak at power frequency; at 6.75 kV peak for a frequency of 500 kHz, and at about 6.6 kV peak for a frequency of 1 MHz for homogenous fields. This supports the theory that the breakdown voltage decreases as the frequency goes up and that the clearance needs to be increased as the frequency goes up for the same electric strength test voltage.

IEC 60664-4 describes a critical frequency f_{crit} at which the reduction in the breakdown voltage for a particular clearance dimension occurs. The critical frequency f_{crit} is calculated as follows:

$$f_{crit} \approx \frac{0.2}{d} \text{ MHz}$$

where d is the clearance distance in mm. For example, for 1 mm clearance, the critical frequency is 200 kHz. But looking at the data in figure A.1 of IEC 60664-4, it appears that the breakdown voltage is almost continuously dropping starting at power frequency. The figure A.1 should have provided more data points in the curves or there should have been an explanation and reason for this drop. Looking at

the data in figure A.2 of IEC 60664-4, it appears that the breakdown voltage first goes up (except for 1 mm and 1.5 mm clearances) and then starts to go down at about 200 k Hz.

As mentioned, the breakdown voltage decreases with increasing frequency. The frequency at which the breakdown voltage is the lowest is designated as f_{min} . The maximum reduction is about 20 percent of the breakdown voltage at power frequencies.^{min} At frequencies above f_{min} , the breakdown voltage goes up (see Figure 1). These are applicable to homogenous and approximate homogenous field conditions. Homogenous field conditions are considered to exist if the radius of curvature of metallic conductors is equal to or greater than 20 percent of the required clearance (see Figure 2).

If a detailed evaluation is not intended and approximate values are considered acceptable, a clearance within the frequency range of 30 kHz to 10 MHz should be designed for 125 percent of the required withstand voltage according to Table F.7 of IEC 60664-1³ or Table 3 of IEC 60664-5.⁴

If a detailed evaluation is intended, the clearance should be designed using the following criteria:

- For frequencies below f_{crit} the clearance should be designed for 100 percent of the required withstand voltage according to Table F.7 of IEC 60664-1 or Table 3 of IEC 60664-5.
- For frequencies above f_{min} the clearance should be designed as for approximate values as given above.
- For frequencies between f_{crit} and f_{min} the clearance should be designed for a withstand voltage that is equal to the required withstand voltage according to Table F.7 of IEC 60664-1 or Table 3 of IEC 60664-5 multiplied by

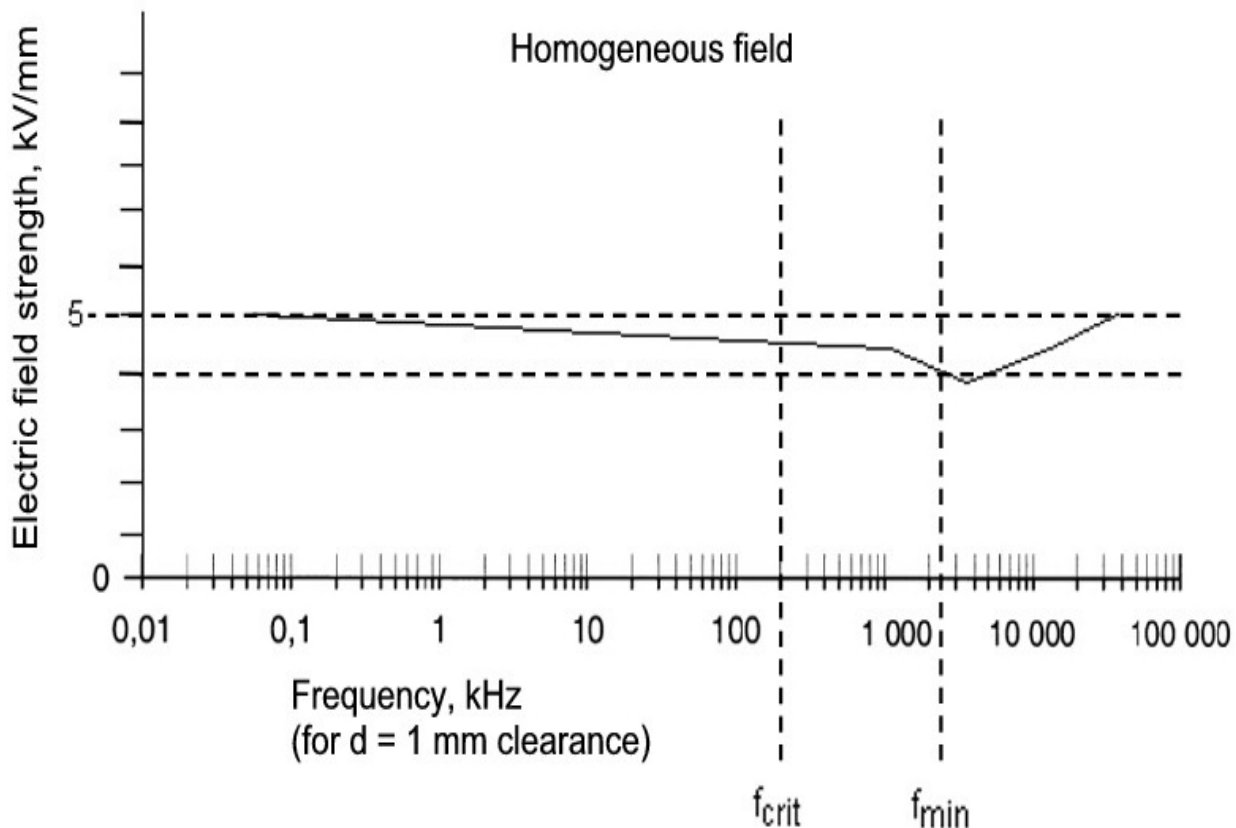

Figure 1. Values of f_{crit} and f_{min}

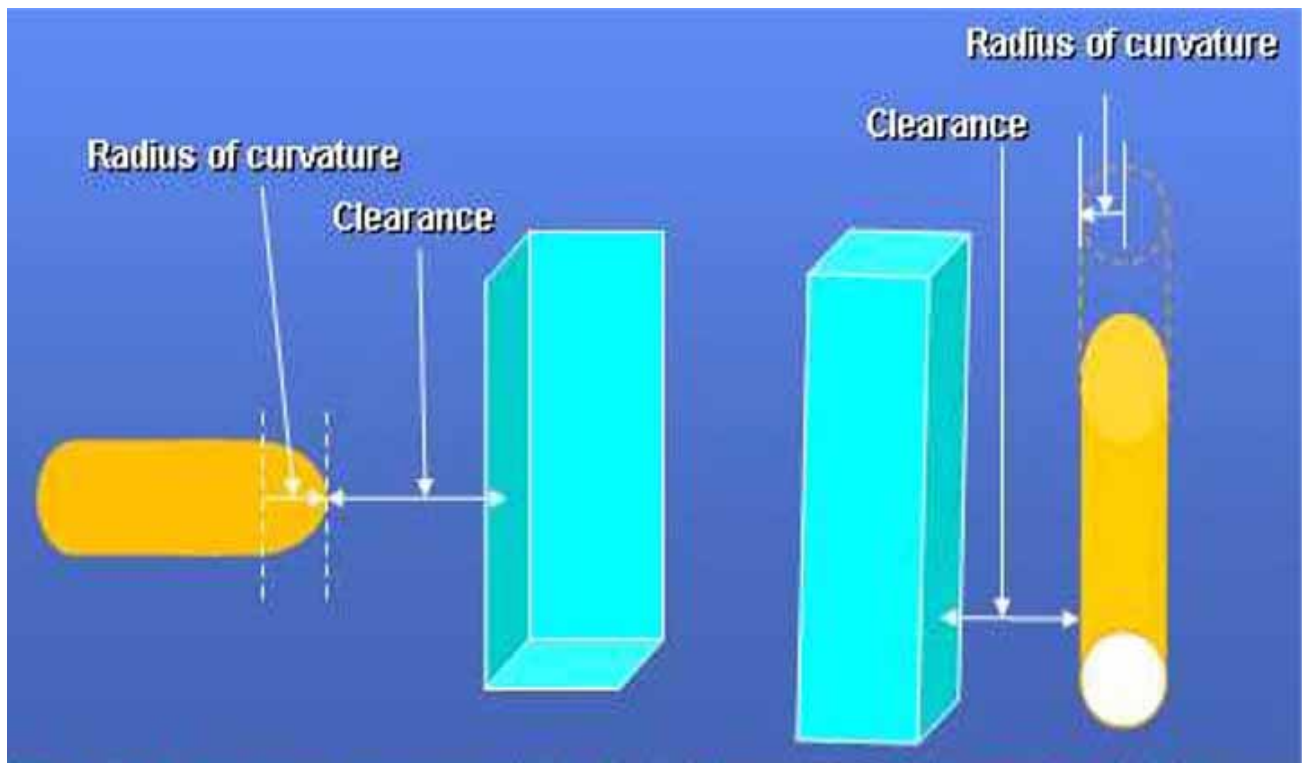

Figure 2. Homogeneous field conditions exist if the radius of curvature of conductors is ≥ 20 percent of the required clearance.

$$1 + \frac{f - f_{crit}}{f_{min} - f_{crit}} \times 0.25$$

The effect of frequency is much stronger for inhomogeneous fields, and the reduction in breakdown voltage is considered to be almost 50 percent of the power frequency breakdown voltage. Table 1 of IEC 60664-4 gives the values of clearances for inhomogeneous electric fields. There is no mention of pollution degrees or any particular frequency. IEC 60664-4 should have included a table for clearances with clearances going up (or down) in value as the frequency goes up (similar to Table 3 for creepage distances). It is not sure if these values are average values of all the frequencies from 30 kHz to 10 MHz or if these are the values at some particular frequency. This way, we may be over-applying the requirements if the frequency is slightly above 30 kHz and may be under-applying the requirements if the frequency is close to 10 MHz.

Table 2 compares the clearances from IEC 60664-4 with the clearances required by IEC 60950-1. Figure 3 shows this comparison of high frequency clearances versus power frequency clearances.

It is apparent that present products at 1400 V or less may not be impacted in terms of clearances. But if the voltage is higher than 1400 V, then clearances at higher frequency of table 3 need to be taken into account.

Creepage distances

In IEC 60664-1, tracking properties of the material (expressed as Comparative Tracking Index, CTI) and pollution degree (surface contamination) are the only criteria used to determine creepage distance

Continued on Page 12



The Internationally Recognized Certification Program for Engineers and Technicians

- PUT YOUR CAREER ON THE FAST TRACK
- GIVE YOUR COMPANY CERTIFIED EXCELLENCE
- OFFER YOUR CUSTOMERS EXCEPTIONAL VALUE

UK: NARTE, Astonbury Manor, Suite 9, Stevenage, SG2 7EH, UK • +44 (0)1438 880757: NARTEinEu@aol.com
Japan: KEC, 6-8-7 nishitenma, kit-ku, Osaka-city 530-0047, Japan • +81-6-6364-2341: kudo@kec.jp
USA Headquarters: NARTE, 167 Village Street, Medway, MA 02053, USA • +1 800-89-NARTE: info@narte.org
For complete information, certification enrollment forms and course study materials, log on to: www.narte.org



IEEE PSES Membership savings

**UL University Offers
IEEE PSES Members
15 Percent Discount**

UL University (ULU) has established a discount code which will provide all IEEE-PSES members with a 15 percent discount off the price of all ULU instructor-led workshops, online programs, videos, books, and other services/products offered under the ULU brand. The discount is automatically applied during registration or purchase of ULU products. Registration or product purchase can be accomplished online at www.uluniversity.com or by calling 888-503-5536 in the U.S. or the country-specific number posted on the ULU website.

To receive the discount, members must enter or mention the discount code found in the Members Only section of the PSES website.

If you or any member has specific questions regarding ULU products or services, please call or email me or call the local country specific number posted on the UL University website.

Tony Robertson
Manager – Customer Training

Advantages of Membership in the IEEE PSES

Makes you part of a community where you will:

- Network with technical experts at local events and industry conferences.
- Receive discounts on Society conferences and symposiums registration fees.
- Participate in education and career development.
- Address product safety engineering as an applied science.
- Have access to a virtual community forum for safety engineers and technical professionals.
- Promotion and coordination of Product Safety Engineering activities with multiple IEEE Societies.
- Provide outreach to interested engineers, students and professionals.
- Have access to Society Publications.



IEEE



E-Mail List: <http://www.ieee-pses.org/emc-pstc.html>
Virtual Community: <http://www.ieee-communities.org/emc-pstc>
Symposium: <http://www.ieee-pses.org/symposium/>

Membership: The society ID for renewal or application is “043-0431”. Yearly society fee is US \$35.

Table 2. Minimum clearances in air at atmospheric pressure for inhomogeneous field conditions

Clearances for basic insulation			
IEC 60664-4		IEC 60950-1	
Working voltage kV peak	Clearance mm	Required withstand voltage kV peak	Clearance mm
Up to 0.6 ^{a, b}	0.065	2680	1.68
0.8 ^a	0.18	2880	1.88
1.0 ^a	0.5	3080	2.08
1.2 ^a	1.4	3280	2.28
1.4 ^a	2.35	3480	2.48
1.6 ^a	4.0	3680	2.68
1.8 ^a	6.7	3880	2.88
2.0 ^a	11.0	4080	3.08

^a For voltages between the values stated in this table, interpolation is permitted.
^b No data is available for voltages U_{peak} of less than 0.6 kV.
 NOTE - The above table is for basic insulation clearances. Clearances for reinforced insulation are double these values.

Note – IEC 60950-1 takes the transients from the mains; and the difference in the mains peak and the peak working voltage into consideration to determine the required withstand voltage, which then is used to determine clearances. For high frequencies, the transients are not taken into account. For this comparison, I have determined the clearances required by IEC 60950-1 to take the transients and the peak working voltage into account for a 230 V system (2.5 kV peak transient of OVCII) as is done at the present.



Figure 3. Comparison of high frequency clearances and power frequency clearances.

for a given voltage. More recent data shows that this is true even under severe environmental conditions and if the materials are not resistant to tracking. For creepage distances less than 2 mm, the breakdown voltage across the surface of the material may be reduced by pollution and IEC 60664-5 takes that reduction into account.

Experimental data shows that the breakdown voltage of the creepage distance is less dependent upon the frequency of the applied voltage, but larger creepage distances are required in order to avoid partial discharge.

However, partial discharge inception voltage not only gets affected but is considerably lower than the breakdown voltage. The partial discharge inception voltage at 1 MHz is only about 66 percent of the partial discharge inception voltage at 100 kHz. This value is reduced by about an additional 30 percent at 3 MHz (about 46 percent of the value at power frequency). The partial discharge occurs before breakdown and degrades the properties of the insulating material. This requires the creepage distances at higher frequencies to be larger than those at power frequency.

Creepage distances should be in accordance with Table 2 of IEC 60664-4. This table does not take into account the influence of tracking, and therefore if the values calculated are smaller than those of Table F.4 of IEC 60664-1 or 60664-5, the values from the latter (Table F.4 of IEC 60664-1 or 60664-5) should be used. This is only for those materials that are deteriorated by heat. For materials such as glass and ceramic that do not deteriorate with heat, Table 1 of IEC 60664-4 for clearances can be used for creepage distances.

Please note that for frequencies up to 400 kHz and voltages up to 900 V peak, the values for creepage distances do not exceed the values of creepage distances in table 2N of IEC 60950-1. Therefore, for voltages up to 900 V peak at up to 400 k Hz, creepage distances of IEC 60950-1 can be used without using table 3 (shown yellow highlighted in Table 3).

NOTE – The Table 2 values are for basic insulation in pollution degree (PD) 1. The values for PD2 and PD3 are obtained by multiplying these values by 1.2 and 1.4 respectively. The values for reinforced insulation are obtained by doubling the values for basic insulation.

Figure 4 shows the different values of creepage distances at 100 k Hz.

Solid insulation

Solid insulation has a higher dielectric constant than air, and so the solid insulation can provide much higher electric field strength than air. However, thickness, temperature of the solid insulation material, and duration of electrical voltage can affect the electric field strength. If there are no voids and gaps then very good insulating materials may have very high electric field strengths.

Voids and gaps result in partial discharges. In layered materials, there may be air gaps when the materials are joined together, which may exhibit the same phenomenon (partial discharge). When a void is present, the voltage divides inversely proportional to the dielectric constant of the insulation. Air having a dielectric constant of one bears the largest voltage drop and tends to get stressed much more and may ionize, leading to partial discharge.

It is already known that the electric field strength of a material goes down as its temperature increases

Table 3. Minimum values of creepage distances for different frequencies ranges

Voltage U_{peak} kV	Creepage distances ^a						
	mm ^b						
	For $30 < f \leq 100$ kHz	For $100 < f \leq 200$ kHz	For $200 < f \leq 400$ kHz	For $400 < f \leq 700$ kHz	For $0.7 < f \leq 1$ MHz	For $1 < f \leq 2$ MHz	For $2 < f \leq 3$ MHz
0.1	0.0167						0.3
0.2	0.042					0.15	2.8
0.3	0.083	0.09	0.09	0.09	0.09	0.8	20
0.4	0.125	0.13	0.15	0.19	0.35	4.5	
0.5	0.183	0.27	0.25	0.4	1.5	20	
0.6	0.267	0.38	0.4	0.85	5		
0.7	0.358	0.55	0.68	1.9	20		
0.8	0.45	0.82	1.1	3.8			
0.9	0.525	1.15	1.9	8.7			
1	0.6	1.15	3	18			
1.1	0.683	1.7	5				
1.2	0.85	2.4	8.2				
1.3	1.2	3.5					
1.4	1.65	5					
1.5	2.3	7.3					
1.6	3.15						
1.7	4.4						
1.8	6.1						

^a The values for the creepage distances in the table apply for pollution degree 1. For pollution degree 2 a multiplication factor of 1,2 and for pollution degree 3 a multiplication factor 1,4 shall be used.

^b Interpolation between rows and columns is allowed.

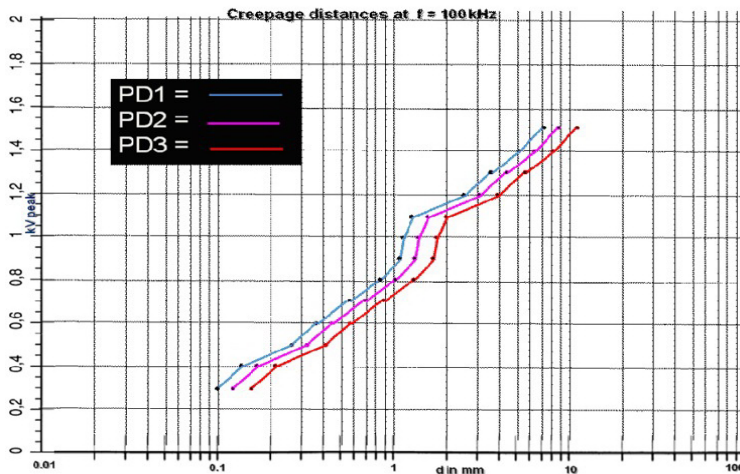

Figure 4. Creepage distances at 100 k Hz for PD1, PD2 and PD3.

and therefore, temperature must be taken into account when determining the electric field strength of solid insulation. Time-to-failure caused by partial discharges is inversely proportional to frequency. The time-to-failure is reduced at higher frequencies if partial discharge can occur. Therefore, material must be free of voids and gaps to avoid partial discharges. According to IEC 60664-4, the short-time breakdown electric field strength at 1 MHz can be as low as 10 percent of the electric field strength at power frequencies.

Another important consideration may be the thickness of the film used for solid insulation. The breakdown electric field strength is related to thickness. For very thin material, the breakdown electric field strength at high frequencies can be higher than thicker materials. In IT equipment, it is common to use two or three layers of very thin films as insulation and this may be the reason that IT industry has not seen any problems in SMPSs that operate at frequencies of 200 to 500 kHz. SMPS operating at 200 kHz to 1 MHz are being used at present.

Two methods to determine acceptable solid insulation

IEC 60664-4 provides two ways to ensure that solid insulation will perform satisfactorily at higher frequencies.

Method 1: Calculate the required thickness of solid insulation at higher frequencies

The first method involves determination of maximum permitted thickness. If the solid insulation thickness is 0.75 mm or more, the electric field strength shall be equal to or less than 2 kV/mm. If the solid insulation is less than or equal to 30 μm , the field strength shall be equal to or less than 10 kV/mm. For thicknesses of solid insulation in between the above two values, the electric field strength E may be calculated as follows:

$$E = \frac{0.25}{d} + 1.667$$

Where E is the electric field strength in kV/mm; and d is the actual thickness of the insulation in mm (see Figure 5).

For example, for a material that has electric field strength of 10 kV/mm, the thickness of insulation shall be less than or equal to:

$$d = \frac{0.25}{10 - 1.667} = 0.03 \text{ mm}$$

Therefore, insulating materials with high electric field strength may not be of much help at higher frequencies. They are required to be thinner and as such may be difficult to fabricate and also too fragile to handle. In addition, the material must not have any voids or gaps.

Table 4 describes the materials presently used at frequencies higher than 30 kHz and also the required thickness in order to comply with the equation given for the electric field strength. It is interesting to know that the thickness of the Kapton (polyimide) material must be decreased in order to meet the high frequency requirements. The maximum electric strength that two layers of Kapton, 0.05 mm can pass is 15 kV and the maximum electric strength that one layer of Kapton 0.025 mm thick can pass 7.5 kV (based on its E value equal to 303 kV/mm at power frequency).

Continued on Page 16

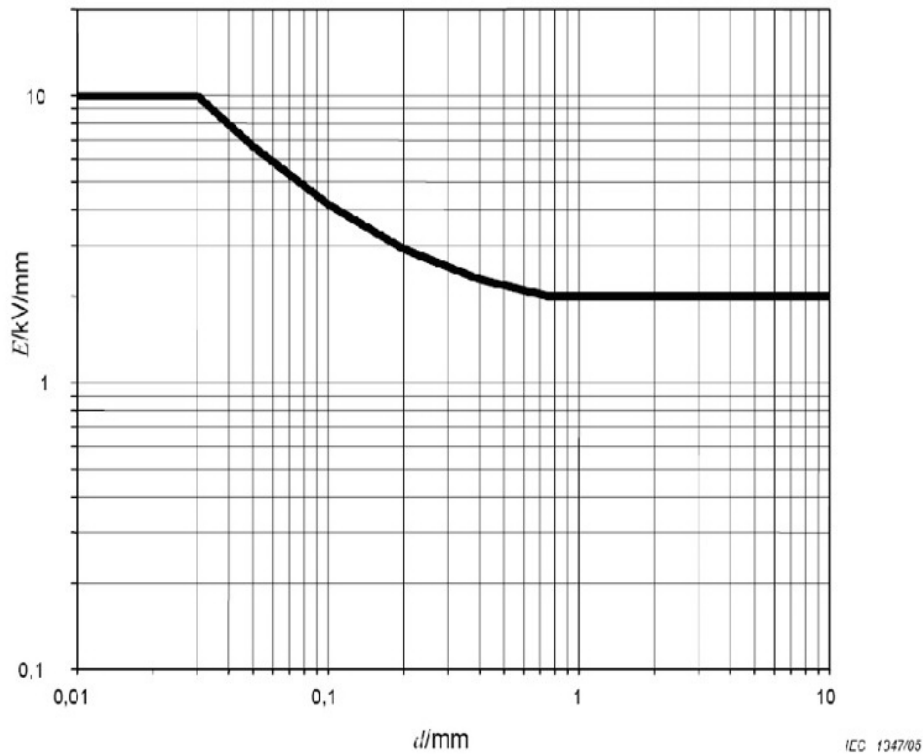

Figure 5. Permissible field strength for dimensioning of solid insulation.

The calculated thickness of 0.00083 mm as per Table 4 (which will comply with IEC 60664-4) will pass only 0.25 kV. That means that we cannot use this thickness at all (for example for a PWB or for a bobbin). In order to pass the 3 kV electric strength test of IEC 60950-1, we need to have a minimum thickness that will pass 3 kV for a single layer. In order to meet IEC 60950-1, a single layer of Kapton, 0.001 mm thick has to be used and that will pass only 3 kV with no margin.

But the value of E used in Table 4 is at power frequency. The value of E goes down as the frequency goes up. Therefore, we should use the value of E which is at the actual frequency used in the application (E_f). Figure C.3 of IEC 60664-4 gives the value of E_f at various frequencies for many different materials. This data can be used to either develop a reduction factor K_f for each different material at different frequencies or come up with an average reduction factor at different frequencies. Tables 5 and 6 present approximate values of reduction factors for different materials as indicated.

Let us recalculate the Table 4 for “Solid insulation thickness requirements” again using the reduction factor at 500 kHz which is our maximum frequency in the example used. For the materials used, the high frequency electric field strength data was not available. Therefore, average value of 0.31 for reduction factor K_f computed from the above Table 5 has been used in the calculations. Looking at the new values of thicknesses obtained in Table 7, even though they are approximately four times the original values in Table 4, these values in Table 7 still need to be reduced in order to meet electric field strength requirements of IEC 60664-4.

In Table 7, Kapton, 0.0027 mm thick will pass an electric strength test of only 0.82 kV at power frequency and 0.26 kV at 500 kHz, and that is much less than the required electric strength test of 6 kV (if we use two layers of 0.00135 mm thick Kapton).

Table 4. Solid insulation thickness requirements

Voltage and frequency	Material	Electric field strength per mm E_p kV/mm	Thickness of solid insulation d mm	Solid insulation test voltage tested for kV	Solid insulation thicknesses from IEC 60664-4 mm	Solid insulation test voltage IEC 60664-4 V peak	Comments
504 to 864 V peak, 200 to 500 kHz	FR530L (bobbin)	33	1 mm	3	0.008	Permits power frequency test on equipment	Thickness needs to be reduced
	TIW	70	3 layers, total 0.11 mm	4.5	0.0037		Thickness needs to be reduced
	Kapton tape	303	2 layers, total 0.05 mm	6	0.00083		Thickness needs to be reduced

Likewise, a FR530L bobbin, 0.03 mm thick will pass only 0.99 kV at power frequencies and 0.31 kV at 500 kHz. I doubt if any material will actually meet the high frequency electric field strength and thickness requirement of IEC 60664-4 and still would have sufficient thickness to meet the electric strength test of various vertical standards. I would rather say it otherwise that the electric field strength of a material should at least be 10 kV/mm or in accordance with Figure 3 of IEC 60664-4 at the desired frequency to be suitable for application at that frequency. Applying equation 3 or Figure 3 of IEC 60664-4 is not really practical.

It was proposed to require the voltage strength V_w determined by multiplying the breakdown electric field strength E_f at the higher frequency with the W actual thickness used in the application to exceed the actual measured V_f peak working voltage V_w at the applicable high frequency. This will be much more practical. This proposal was accepted. By doing this we are ensuring that the reduced breakdown field strength and therefore, the reduced actual voltage strength V_w of the actual thickness used, is still

Table 5. Reduction factors to determine E_f at higher frequencies

Material ^a	Frequency in kHz										
	30	100	200	300	400	500	1000	2000	3000	5000	10,000
	Reduction factor K_f at higher frequencies										
Porcelain	0.52	0.42	0.40	0.39	0.38	0.37	0.36	0.35	0.35	0.34	0.30
Silicon-glass	0.79	0.65	0.57	0.53	0.49	0.46	0.39	0.33	0.31	0.29	0.26
Phenolic	0.82	0.71	0.53	0.42	0.36	0.34	0.24	0.16	0.14	0.13	0.12
Ceramic	0.78	0.64	0.62	0.56	0.54	0.51	0.46	0.42	0.37	0.35	0.29
Teflon	0.57	0.54	0.52	0.51	0.48	0.46	0.45	0.44	0.41	0.37	0.22
Melamine-glass	0.48	0.41	0.31	0.27	0.24	0.22	0.16	0.12	0.10	0.09	0.06
Mica	0.69	0.55	0.48	0.45	0.41	0.38	0.34	0.28	0.26	0.24	0.20
Paper Phenolic	0.58	0.47	0.40	0.32	0.26	0.23	0.16	0.11	0.08	0.06	0.05
Polyethylene	0.36	0.28	0.22	0.21	0.20	0.19	0.16	0.13	0.12	0.12	0.11
Polystyrene	0.35	0.22	0.15	0.13	0.13	0.11	0.08	0.06	0.06	0.06	0.06
Glass	0.37	0.21	0.15	0.13	0.11	0.10	0.08	0.06	0.05	0.05	0.04
Other materials	0.57	0.46	0.40	0.36	0.33	0.31	0.26	0.22	0.21	0.19	0.16

This data is for materials that are 0.75 mm thick.

Continued on Page 18

Table 6. Reduction factors to determine E_F at higher frequencies for thin foils

Thin foil material	Frequency in kHz										
	30	100	200	300	400	500	1000	2000	3000	5 000	10,000
	Reduction factor K_F at higher frequencies										
Cellulose-acetobutyrate (0.03 mm)	0.67	0.43	0.32	0.27	0.24	0.20	0.15	0.11	0.09	0.07	0.06
Cellulose-acetobutyrate (0.06 mm)	0.69	0.49	0.36	0.30	0.26	0.23	0.17	0.13	0.11	0.08	0.06
Polycarbonate (0.03 mm)	0.61	0.39	0.31	0.25	0.23	0.20	0.14	0.10	0.08	0.06	0.05
Polycarbonate (0.06 mm)	0.70	0.49	0.39	0.33	0.28	0.25	0.19	0.13	0.11	0.08	0.06
Cellulose-triacetate (0.03 mm)	0.67	0.43	0.31	0.26	0.23	0.20	0.14	0.10	0.09	0.07	0.06
Cellulose-triacetate (0.06 mm)	0.72	0.50	0.36	0.31	0.27	0.23	0.17	0.13	0.10	0.10	0.06
Other thin foil materials	0.68	0.46	0.34	0.29	0.25	0.22	0.16	0.12	0.10	0.08	0.06

higher than the actual measured high frequency peak working voltage V_{PW} . This way the manufacturer can use higher thickness to meet the electric strength test at the power frequency and also insure that V_W is always greater than V_{PW} .

This is determined as given below:

$$E_F = E_P \times K_F$$

Where

- E is the solid insulation breakdown electric field strength (rms) at power frequency;
- E^P is the solid insulation breakdown electric field strength (rms) at the applicable high frequency;
- K_F is the reduction factor at the applicable high frequency from Table 5 or Table 6 above.

Other variables used are as follows:

Table 7. Solid insulation thickness requirements (using reduction factors)

Voltage and frequency	Material	Electric strength E_F at 500 kHz	Actual thickness of solid insulation	Solid insulation test voltage	Solid insulation thickness from IEC 60664.4	Solid insulation test voltage IEC 60664.4	Comments
		kV/mm	mm	kV	mm	V peak	
504 to 864 V peak, 200 to 500 kHz	FR530L	10.296	1 mm	3	0.030	Permits power frequency test on equipment	Thickness needs to be reduced
	TIW	21.84	3 layers, total 0.11 mm	4.5	0.0124		Thickness needs to be reduced
	Kapton tape	94.536	2 layers, total 0.05 mm	6	0.0027		Thickness needs to be reduced

V^W is the actual voltage strength (peak) of the actual thickness of the material at the applicable high frequency ($V^W = E \times d \times 1.414$);

V^W is the measured peak working voltage at the applicable higher frequency across the insulation;

d is the actual thickness of solid insulating material in mm.

For calculating the value of E_F , we must know the value of E_P . The actual voltage strength V^W for the actual thickness used must be greater than the peak working voltage V^{PW} at the applicable high frequency. A factor of 20 percent can be used for basic or supplementary insulation and also for the reinforced insulation after doubling the peak working voltage V^{PW} .

Summary of method 1 (calculation of thickness)

a) Determine the value of E_P in kV/mm for the insulating material at power frequency at the applicable thickness. Use the actual value of E_P for the material from the tables (or you need to determine this). If not available, use the value of E_P for the 0.75 mm thickness

b) Determine the reduction factor K_F for the electric field strength of the insulating material at the applicable frequency from Table 5 or Table 6 as applicable. If the material is not the one listed in table 2 or 3, use the value of K_F in the last row of the Table 5 or Table 6 as applicable.

c) Determine the electric field strength E_F at the applicable frequency by multiplying the value E_P at the power frequency by the reduction factor K_F .

$$E_F = E_P \times K_F$$

d) Determine the actual voltage strength V^W of the insulating material by multiplying the value E_F by the actual thickness (d in mm) of the insulating material (at the applicable higher frequency).

$$V^W = E_F \times d \text{ (where } d \text{ is the actual thickness in mm)}$$

e) For basic insulation or supplementary insulation, V^W shall exceed the measured high frequency peak working voltage V^{PW} by 20 percent.

$$V^W > 1.2 \times V^{PW}$$

f) For reinforced insulation, V^W shall exceed twice the measured high frequency peak working voltage V^{PW} by 20 percent.

$$V^W > 1.2 \times 2 \times V^{PW}$$

The 20 percent factor is to provide a safety margin.

Therefore, the solid insulation which is subjected to both power frequencies and higher frequencies (for example, a PWB) must meet the solid insulation requirements at power frequencies and in addition the requirements at actual higher frequencies used in the application. Some values of E_P are given in Table 8.

Method 2: Perform electric strength testing of solid insulation at higher frequencies

The second method involves actual electric strength or partial discharge testing at higher frequencies. Capacitive load is very large at higher frequencies, so testing is limited to only small components and subassemblies. For complete equipment, IEC 60664-4 permits the electric strength test at the power

frequency voltage in accordance with 4.1.2 of IEC 60664-1. This is a bit strange, as this test is already being conducted on all IT equipment. High frequency electric strength test equipment is complicated and may require several transformers to give you a sufficiently high voltage output at each desired frequency. But since it is permitted to conduct the test at power frequency (for complete equipment), it is not clear if component and subassemblies still need to be tested for the high frequency dielectric strength test. IEC 60950-1 also has a similar test for solid insulation conducted at power frequencies.

The high frequency electric strength test equipment involves the building of several high frequency resonant transformers for obtaining a high voltage output at the desired frequency to cover the entire range. It is very hard to do the testing due to the strong reaction between the impedance of the component under test and the frequency and output voltage of the resonant transformer.

Table 8. Electric field strength E_p for some commonly used materials

Material	Electric field strength E_p kV/mm (rms)				
	Thickness of the material in mm				
	0.75	0.08	0.06	0.05	0.03
Porcelain	9.2	-	-	-	-
Silicon-glass	14	-	-	-	-
Phenolic	17	-	-	-	-
Ceramic	19	-	-	-	-
Teflon	27	-	-	-	-
Melamine-glass	27	-	-	-	-
Mica	29	-	-	-	-
Paper phenolic	38	-	-	-	-
Polyethylene	50	-	-	52	-
Polystyrene	55	65	-	-	-
Glass	60	-	-	-	-
Polyethylene	49	-	-	-	-
Kapton	303	-	-	-	-
TIW	70	-	-	-	-
FR 530L	33	-	-	-	-
Mica-filled phenolic	28	-	-	-	-
Glass-silicone laminate	18	-	-	-	-
Cellulose-acetobutyrate	-	-	120	-	210
Polycarbonate	-	-	160	-	270
Cellulose-triacetate	-	-	120	-	210

NOTE It is assumed that materials are equal to or thicker than 0.75 mm where no thickness has been mentioned. Such materials that do not have E_p information at very small thickness actually have a better E_p value at the small thickness than the E_p value at 0.75 mm thickness. This table needs more data.

A high frequency high power oscillator can also be used as described in IEC 60664-4. Table D.1 in IEC 60664-4, given as Table 9 below, is provided for this oscillator's output. The total load impedance is tuned to a desired frequency. However, it should be made clear as to what test voltage needs to be used in relation to the actual measured peak working voltage at the high frequency across the insulation.

For high frequency testing IEC 60664-4 makes the following statement: "Due to the large capacitive load at high-frequency, high-frequency testing is primarily applicable to components and subassemblies. If an additional high-voltage test on complete equipment is required, this test can be performed according to 4.1.2 of Part 1 with power frequency voltage."

Continued on Page 24

IEC 60664-4 permits the verification of clearances by an electric strength test if the required withstand voltage is increased to 125 percent of the required value. IEC 60664-4 should have given a similar verification method for electric strength for solid insulation at power frequency but raising the required withstand voltage to 125 percent of the required value. That may be very practical rather than using expensive, complicated equipment for high frequency electric strength test.

From the above, it is clear that we should follow the clearance and creepage distances of the tables given in IEC 60664-4. For solid insulation, we should continue to conduct the electric strength test of IEC 60950-1 or IEC 60065⁶. Electric strength test requirements of IEC 60950-1 are going to be aligned with future IEC 62368⁷ and those will be aligned with the upcoming IEC 60664-2-1⁵ with respect to the electric strength. TC96 (basic safety committee for transformers), in developing requirements for high frequency in their standard 96/275A/CDV for IEC 61558-2-16⁸ is following somewhat similar approach.

Solid insulating materials suitable for high frequencies should have the following properties:

- High electric field strength (kV/mm);
- Process-ability (easy film forming);
- Suitability for forming electronic parts.

Some examples of materials used in high frequency applications are polyimide filled with fluorine cores; PTFE; ePTFE; cyanate; AlInN/GaN; the materials mentioned in the tables above.

TC96, technical committee for transformers and switch mode power supplies, is also going through the

Table 9. Data of the test voltage source (Table D.1 of IEC 60664-4)

Frequency	Coupling capacitance pF	Maximum test voltage kV	Required test current A
100 kHz	1100	2.7	1.9
200 kHz	1100	4.0	5.5
500 kHz	450	3.4	4.8
1 MHz	520	2.7	8.8
3 MHz	320	1.0	6.0

process of adopting the requirements of IEC 60664-4, except the high frequency electric strength test.

Conclusion

As the frequency goes up, the voltage withstand capability of a clearance starts to go down. Therefore, for the same withstand voltage, clearance has to be increased. Creepage distances are also required to be larger than what they are at the power frequency because the partial discharge initiating voltage goes down with increasing frequency.

Insulating materials deteriorate in electric strength properties when subjected to high frequency voltages. Solid insulation properties degrade as the frequency goes up. Designers should design their circuits using the right materials that are free of voids and gaps to avoid deterioration and damage by partial discharges (partial discharge may occur if the voltage is more than 500 V peak). The breakdown electric

Continued on Page 22

field strength at the applicable frequency multiplied by the actual thickness used should be greater than the peak working voltage measured at the applicable high frequency.

Lal Bahra is a P. Eng. in Global Regulations and Standards at Dell Inc.

References:

- ¹ IEC 60950-1: 2005, *Information Technology Equipment – Safety – Part 1: General requirements*
- ² IEC 60664-4: 2005, *Insulation coordination for equipment within low-voltage systems – Considerations of High Frequency Voltage Stress*
- ³ IEC 60664-1: 2007, *Insulation coordination for equipment within low-voltage systems - Part 1: Principles, requirements and tests*
- ⁴ IEC 60664-5: 2007, *Insulation coordination for equipment within low-voltage systems — Part 5: A comprehensive method for determining clearances and creepage distances equal to or less than 2 mm*
- ⁵ 109/66/CD for IEC TR 60664-2-1, *Insulation coordination for equipment within low-voltage systems – Part 2-1: Application guide - Explanation of the application of the IEC 60664 series, dimensioning examples and dielectric testing*
- ⁶ IEC 60065: 2005, *Audio, video, and similar electronic equipment – Safety requirements*
- ⁷ IEC 62368 (108/276/CDV): *Audio/video, Information and Communication Technology Equipment – Safety - Requirements*
- ⁸ 96/275A/CDV for IEC 61558-2-16: *Safety of transformers, reactors, power supply units and similar products for voltages up to 1100 V – Part 2-16 Particular requirements and tests for switch mode power supply units and transformers for switch mode power supply units*

News and Notes

Society

When renewing your IEEE membership...

It's the renewal time of the year—a good time to make sure that the PSES is noted in your IEEE technical interest profile. You can easily update your technical interest profile to include Product Safety Engineering. Just log on to your account using “My IEEE.” Select “Update Profile” to revise your technical interest profile to include Product Safety Engineering.

Notes

Neither rain nor wind...

Gary Schrempp, 2008 IEEE PSES Symposium Chair reports questions as to whether Hurricane Ike affect the 2008 symposium. “Our symposium was unaffected, and will be held as scheduled,” he says, also noting that advance registrations are coming in at a rate far in excess of last year.

What's new

Role of Warnings and Instructions course is scheduled

The University of Wisconsin College of Engineering Department of Engineering Professional Development will offer its well-regarded course on warnings and instructions November 5–7, 2008 at the university's Madison, WI campus. In addition to general course materials, participants in the three-day course will receive copies of the ANSI Z535.4 standard for product safety signs and labels and the ANSI Z535.6 standard for safety information in product manuals. For more information, visit <http://epd.engr.wisc.edu/webK007> or call Program Director Jeff Oelke at 800-462-0876. (See the December 2006 issue of *PSEN* for an article about this course.)

Harmonized appliance standard for North America almost ready

A North American 60335-1 (*Household and similar electrical appliances – Safety – Part 1: General requirements*) standard, being prepared under the auspices of CANENA (www.canena.org) is edging closer to publication. Representatives from ANCE, CSA, UL, trade groups, and companies in Canada, Mexico, and the U.S. met in July in the Washington, DC area to address comments received on the draft that been circulated for comment.

Not all of the comments could be addressed at the two-day meeting, so it was followed by a teleconference in August. Chairman Mark Hinkleman says that one more teleconference is likely to be sufficient to finish the work, and publication of the standard is expected during 2009. This standard will ultimately reach many product areas—more than a hundred product-specific Part 2 standards are associated with the IEC 60335-1 standard.

Touch Current Measurement Comparison Part 2

Touch Current Measurement Comparison: Looking at IEC 60990 Measurement Circuit Performance, Part 2: Electric Shock

by Peter E. Perkins, PE

Abstract

This article examines in some detail the performance of IEC 60990 circuits, considering specific conditions or waveforms. Conditions of electric burn (eBurn) plus touch current response by these circuits are shown. Examples are provided to show a range of waveforms and their calculated response.

The discussion is divided into two parts: Part 1, Electric Burn (eBurn), then Part 2, Electric Shock TC (EStc) comparisons across two circuits—startle-reaction circuit and let-go circuit. These results are compared to a TC waveform to show a relation to modern electronic equipment.

This article confirms the continued need for peak measurements for TC waveforms from electronic equipment.

PART 2: ELECTRIC SHOCK

IEC 60990 provides two touch current measurement circuits which meet the frequency factor curves of IEC 60479 under the following conditions.

- A circuit weighted for startle-reaction (formerly called perception-reaction), Figure 4 in IEC 60990, which is called s-r in this article.
- A circuit weighted for let-go, Figure 5 in IEC 60990, called l-g here.

From Figure 3 of Part 1 of this article, reproduced here, startle-reaction is defined by curve a (the 0.5 mA line). Let-go is defined by curve b (which is 5 mA under steady state conditions but can go much higher under short-time contact). The c curves identify the region of ventricular fibrillation (VF) which is fatal if not quickly reversed.

The human body can take more current at higher frequency for the same effect. The curves of Figure 8 are from IEC 60990 and show the frequency factor for startle-reaction as well as the adequacy of the IEC 60990 circuits in adjusting the high frequency components according to this curve.

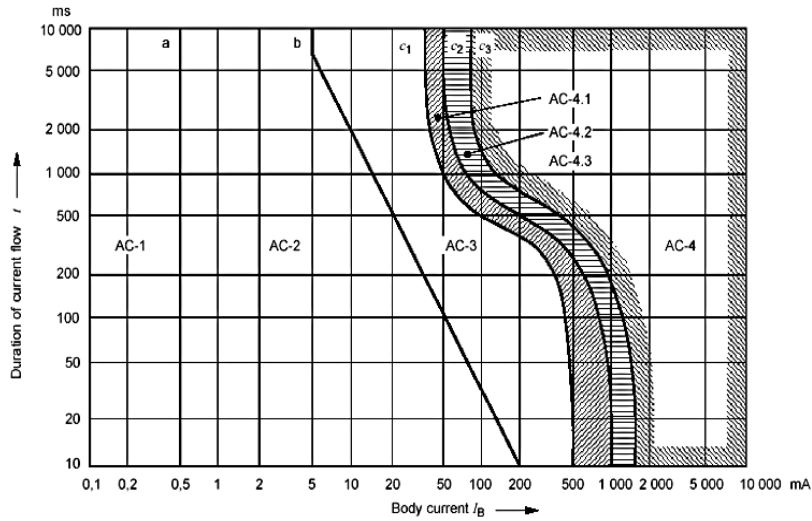

Figure 3. LF ac duration vs. body current (IEC 60479-1, Figure 20). The reader is referred to IEC 60479 for details of graph nomenclature not discussed in this article.

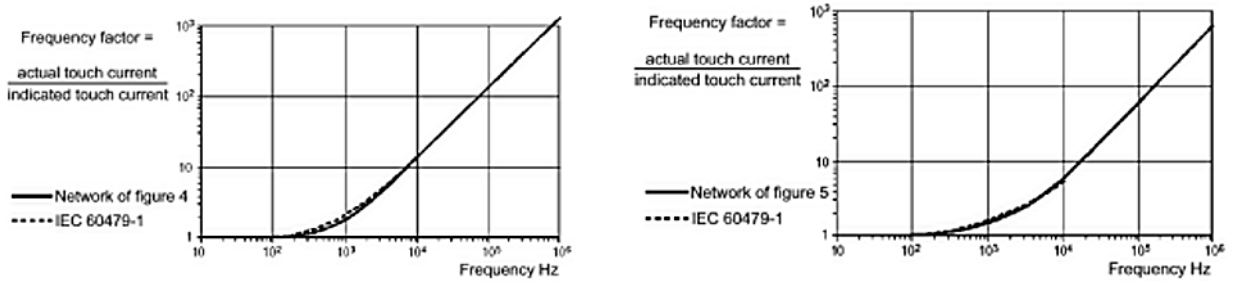
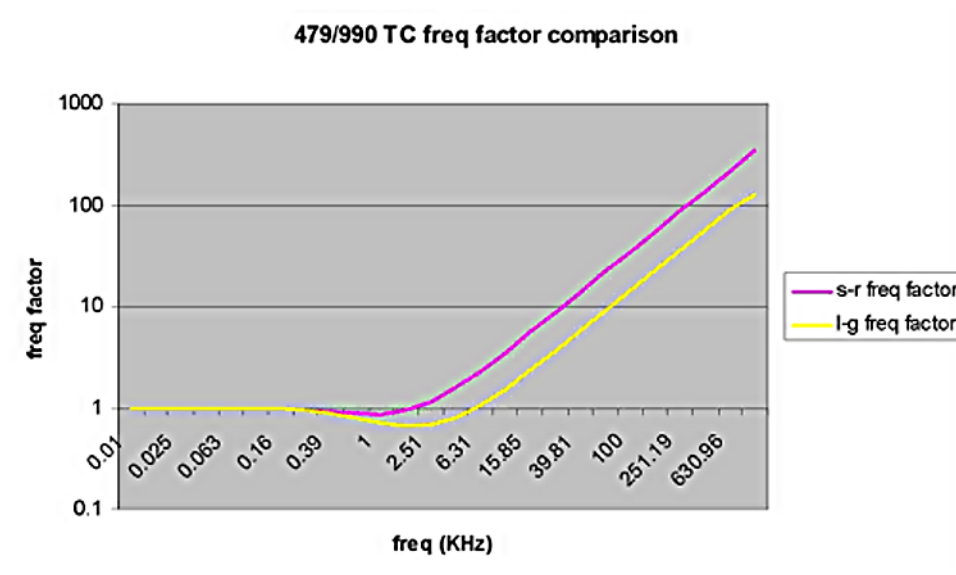

Figure 9 gives a comparison of the frequency factor curves for startle-reaction and let-go circuits.



Continued on Page 28

Sponsored by the IEEE Product Safety Engineering Society
26-28 October 2009 Toronto Ontario Canada
Hotel TBD

Chair

Doug Nix
dnix@ieee.org

Co-Chair

Steve Brody
steven.brody@brooks.com

Treasurer

Murlin Marks

Secretary

Brian Greaney
brian.a.greaney@hp.com

Technical Program

Bob Griffin
bobgriff@us.ibm.com

And

Gary Tornquist
garytor@microsoft.com

**Product Safety 101
Technical Program**

Rich Nute, richn@ieee.org

Exhibits/Promotions

Thomas Ha
tom@gmcompliance.com

Exhibitor Manager

Sue Kingston
s.kingston@ieee.org

Registration

Diana Krynski
d.krynski@ieee.org

Arrangements/Logistics
TBD**Communications,
Webmaster and Program
Records**

Dan Roman
Dan.Roman@ieee.org

At-Large Members

Jim Bacher
Jack Burns
Daniece Carpenter
Elya Joffe
Henry Benitez
Ken Thomas

Call for Papers, Workshops, and Tutorials

The IEEE Product Safety Engineering Society seeks original, unpublished papers and tutorials on all aspects of product safety and compliance engineering including, but are not limited to:

- **Product Safety:** Consumer, medical, computer (IT), test and measurement, power supplies, telecommunication, industrial control, electric tools, home appliances, cellular and wireless, etc.
- **Product Safety 101:** Papers / presentations intended for new safety engineers. This will include certification processes, product evaluation and testing, report writing, and working with designers to get it right the first time.
- **Safety Subjects:** Electrical, mechanical, fire, thermal, chemical, optical, software, functional, reliability, etc.
- **EMC / RF:** Electromagnetic emissions, electromagnetic immunity, regulatory, Introduction to EMC/RF for the safety engineer and compliance engineer.
- **Components:** Grounding, insulation, opto-couplers, capacitors, transformers, current-limiters, fuses, power line filters, ferrite, environmental, electromagnetic emissions, electromagnetic immunity, regulatory, etc.
- **Certification:** Product safety, electromagnetic emissions, electromagnetic immunity, environmental, processes, safety testing, regulatory, etc.
- **Standards Activities:** Development, interpretations, status, interpretations, country requirements, Laboratory Accreditation, etc.
- **Safety Research:** Body physiological responses to various hazardous energy sources, unique safeguard schemes, etc.
- **Environmental:** RoHS, WEEE, EuP (Energy-using Products), Energy Star, Packaging Directives, REACH (Chemical), CeC, etc.

Mark your calendars to attend the
2009 IEEE Symposium on Product Compliance Engineering.

Author's Schedule

Intent to present and topic (e-mail) April 29, 2009

Draft e-paper June 1, 2009

Notification of Acceptance July 6, 2009

Complete e-paper August 17, 2009

See <http://www.ieee-pses.org/symposium/index.html#CFP> for more details on requirements and dates.

www.ieee-pses.org/symposium

2004 / 2005 / 2006 / 2007 IEEE-PSE Symposium

CD Purchasing Information

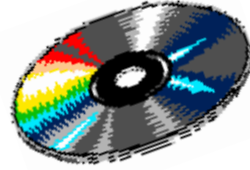

SYMPOSIUM PAPERS ON CD:

The Product Safety Engineering Society continues to offer the 2004 IEEE PSES records for sale. The cost for the CD is \$35 plus shipping and handling for IEEE members; \$50 plus shipping and handling for non-IEEE members. At this time, check or money orders are the means for payment. Please provide the following information:

CDs to be shipped to- (Please print or type.)

Name: _____

Mailing address: _____

IEEE member number: _____

Shipping and handling: \$5 per CD

Payment: Check or money order.

Make Check or money order to: "IEEE Product Safety Society"

Quantity 2004: _____ x \$35 = _____ for IEEE members

Quantity 2004: _____ x \$50 = _____ for non-IEEE members

Quantity 2005: _____ x \$35 = _____ for IEEE members

Quantity 2005: _____ x \$50 = _____ for non-IEEE members

Quantity 2006: _____ x \$35 = _____ for IEEE members

Quantity 2006: _____ x \$50 = _____ for non-IEEE members

Quantity 2007: _____ x \$35 = _____ for IEEE members

Quantity 2007: _____ x \$50 = _____ for non-IEEE members

S&H: QTY _____ x \$5 = _____

Total = _____

Send payment to:

IEEE Product Safety Engineering Society
c/o Richard Georgerian, PSES Board of Directors
7103 Sioux Court
Longmont, CO 80504
U.S.A.

Depending on stock availability allow 2 to 3 weeks for delivery.

The TC comparison is shown in Figure 10 for the same input conditions.

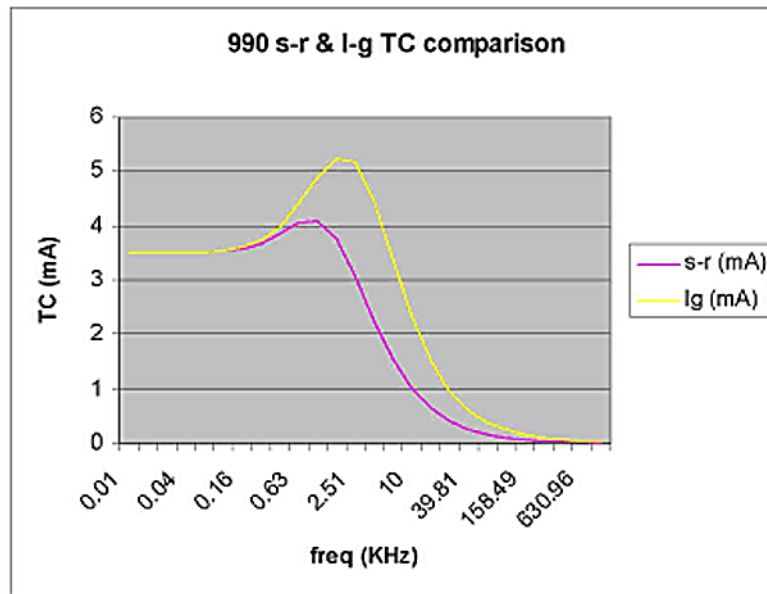

Sinusoidal waveforms

The IEC 60990 circuits meeting the frequency factor curves just described are shown in Figure 11. In each circuit the basic body model has a high frequency filter attached to meet the appropriate requirements.

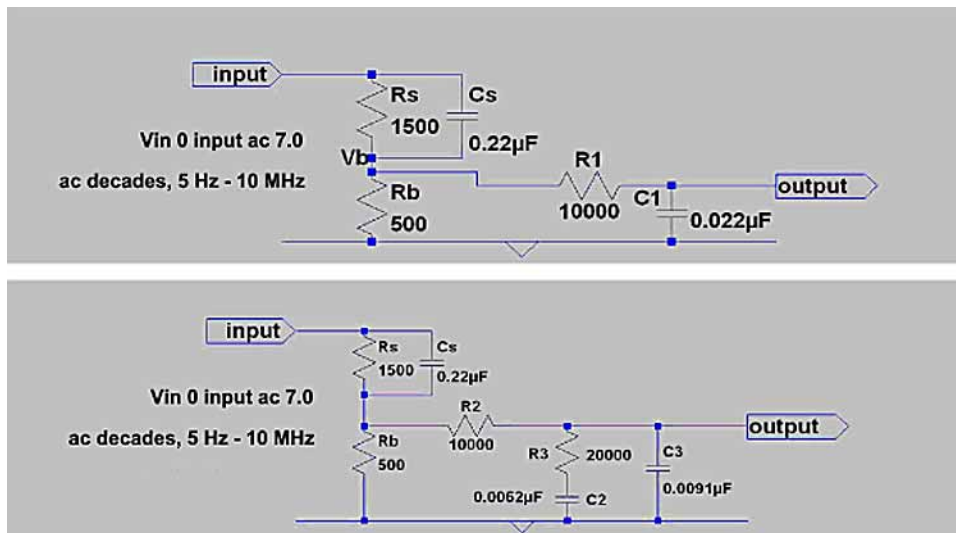

The performance of each circuit is shown in Figure 12 for the specific case chosen. For this discussion, the case of 3.5 mA touch current has been selected. This case pushes the startle-reaction situation beyond the 0.5 mA expected, but has been commonly used in IEC standards such as IEC 60950 and IEC 61010.

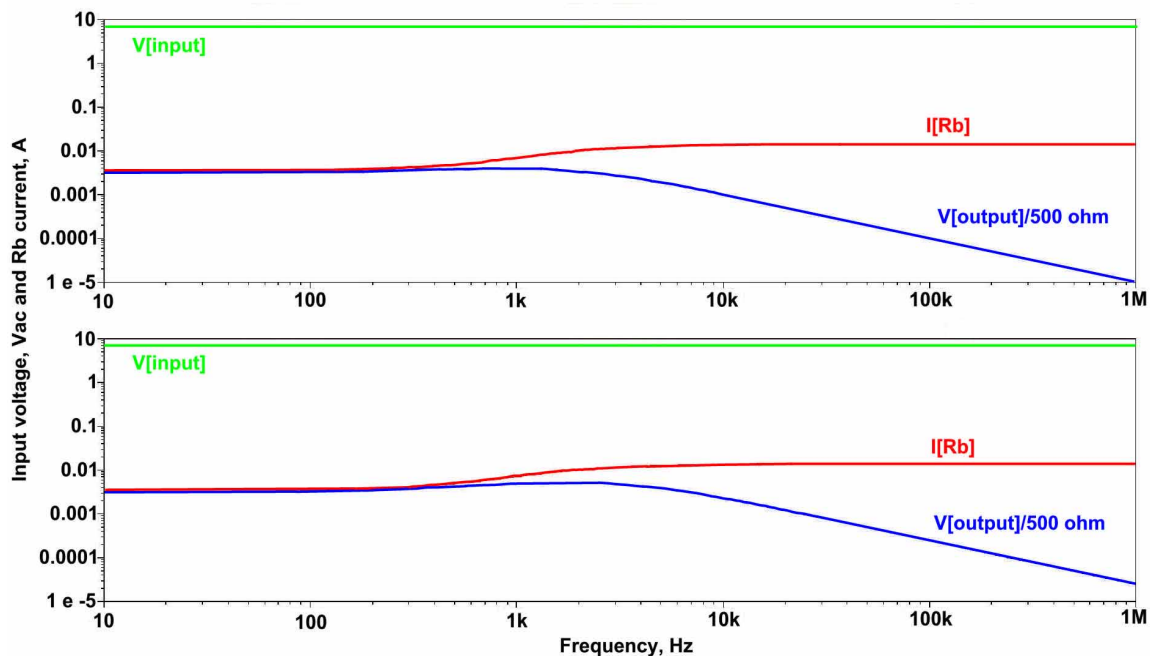

Figure 12. IEC 60990 measurement response:
 startle-reaction circuit, upper; let-go circuit, lower.
 (Ed note: the vertical axis also should note $t_c = V(\text{output})/500\text{ohm}$ also in A)

Note that the touch current curve (the $V(\text{output})/500\text{ohm}$, blue curve) is falling. The circuit has been designed to be the inverse of the frequency factor curve so that the same value can be read from the meter and compared to the limit irrespective of the frequency of the TC signal.

In this case we expect the rms TC to be 3.5 mA and the peak value to be square root of $2 * \text{rms} = 5 \text{ mA}$. The peak/rms ratio should then be the square root of 2 as shown in Table 5. The s-r curve should be used for cases where the TC limit is 2 mA or less and the l-g circuit above that. This will ensure that children will be able to let go of the circuit when touched.

In all of the cases examined here, there will be an emphasis on peak measurement, as the body responds to peak values of current for electric shock, not rms values.

In each case shown in Figure 13 we see the 50 Hz fundamental and no harmonics.

Table 5. 50 Hz sine wave TC

Current	Peak	rms	Peak/rms ratio
s-r circuit TC = $I_{V(\text{output})/500 \Omega}$	4.94 mA	3.49 mA	1.415
l-g circuit TC = $I_{V(\text{output})/500 \Omega}$	4.96 mA	3.50 mA	1.417

Figure 14 looks at a 100 kHz sine wave input to each circuit. (The input voltage clearly defines the generating waveform being considered for each case.) Comparing the peak and rms values of each waveform for each circuit as before.

The frequency factor filter circuit (see IEC 60990 which developed these circuits) reduces the TC value, as discussed earlier, at this frequency as shown in Table 6.

Continued on Page 30

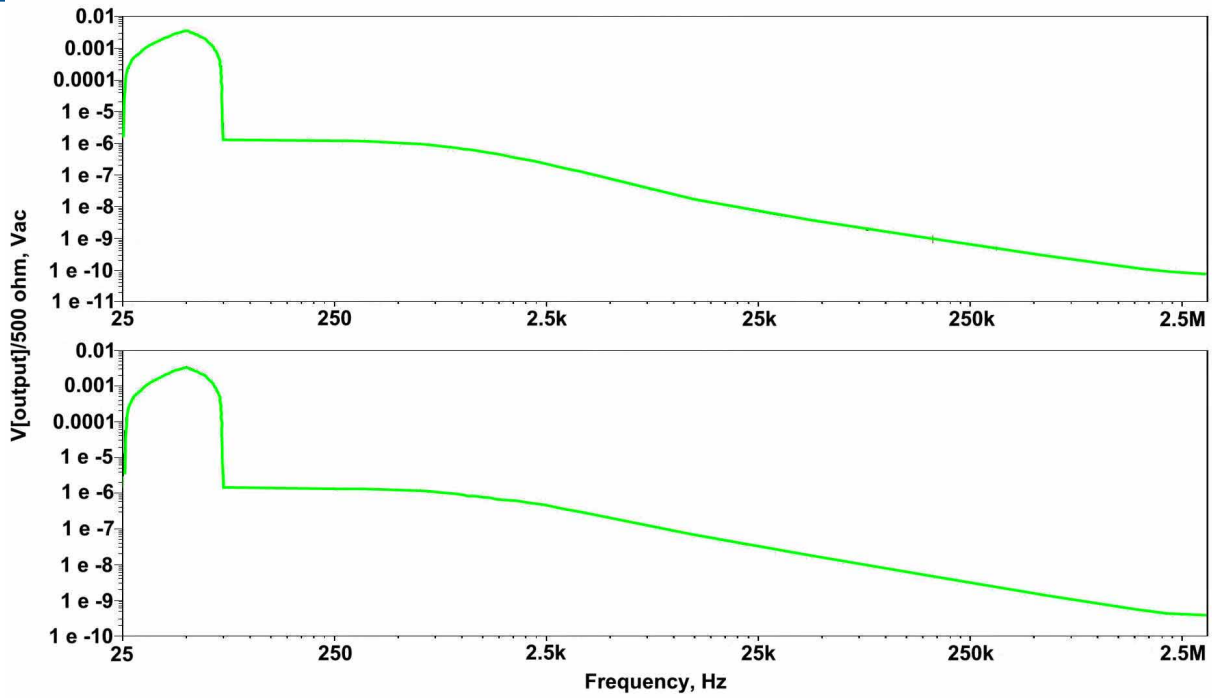

Figure 13. 50 Hz sine wave FFT:
startle-reaction circuit, upper; let-go circuit, lower.

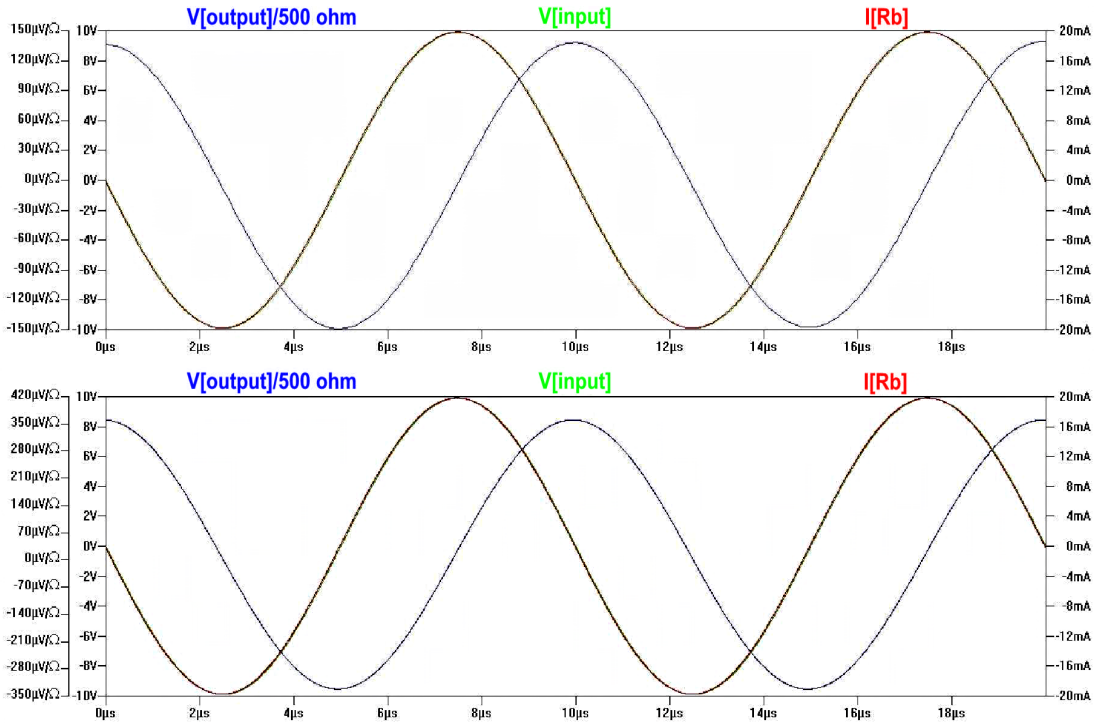

Figure 14. 100 kHz sine wave response:
startle-reaction circuit, upper; let-go circuit, lower.

Note that the input current curve (I[Rb]) and the TC current curve (V(output)/500ohm) are laid upon one another and appear to be a

Each circuit treats the TC value in a different way—the TC is higher for the let-go measurement. The increased current starting with the middle frequencies increases the total current. The peak/rms ratio is still square root of 2. Again, only the fundamental frequency appears in the FFT as shown in Figure 15.

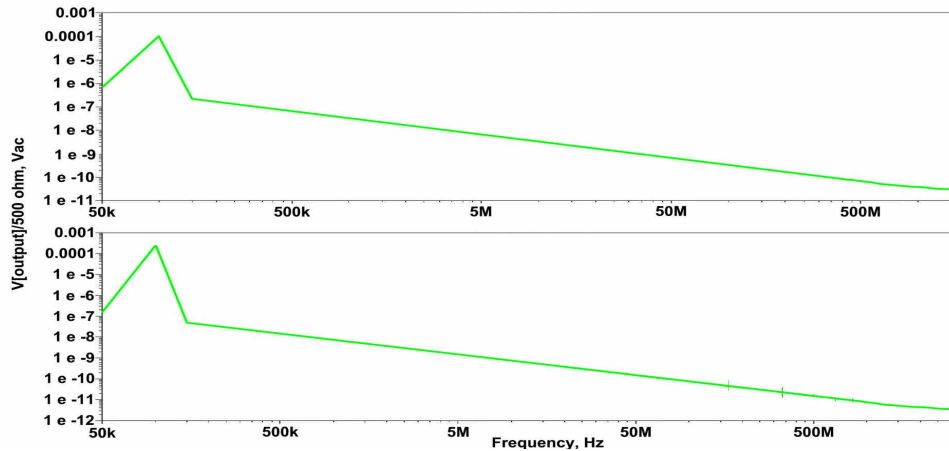

Figure 15. 100 kHz sine wave FFT: startle-reaction circuit, upper; let-go circuit, lower.

Triangular waveforms

The triangular waveform might be considered a “stretched out” sine wave, as indicated by the values shown in Table 7.

Table 7. 100 kHz sine wave TC

Current	Peak	rms	Peak/rms ratio
s-r circuit TC = $I_{V(\text{output})/500 \Omega}$	4.98 mA	2.868 mA	1.736
l-g circuit TC = $I_{V(\text{output})/500 \Omega}$	5.05 mA	2.869 mA	1.760

Triangular waveforms are found in some equipment drawing substantial regulated power for heaters or similar loads. For this case the rms TC is lower than the 3.5mA that would be allowed while the peak value is higher—about 5mA, one value below and one above as shown in Figure 16. The peak/rms ratio is no longer square root of 2.

Somewhat to our surprise, Figure 17 shows that there are considerable harmonics associated with the triangular waveform. The filter circuit component of the TC circuits properly acts on these high frequency components of each waveform.

Square waves

The response to a line frequency square wave is shown in Figure 18. (Technically any frequency in the range from 20–30 Hz to 80–100 Hz is dealt with about the same way; I usually

Continued on Page 33

New PSES Members from 30 June 2008 Through 30 September 2008

Our new members are located in the following countries: Australia, Canada, Czech Republic, Saudi Arabia, Taiwan, United Kingdom, USA

- Alexandr Knapek
- Bimal S. Patel
- Bunh T Ma
- Christopher Nathan Arldt
- Fahad Abdullah Al-Mogairen
- Flore Chiang
- George Edward Page
- Gerardo G Vuolo
- Joseph T Samosky
- Ken Budoff
- Matthew Olson
- Normand Juneau
- Patricia Knudsen
- Paul A Corbet
- Rick Cooper
- Robert J Nelson
- Sanne Cubberley
- Son Bang La
- Tac Van Pham
- Warren Richard Gartman

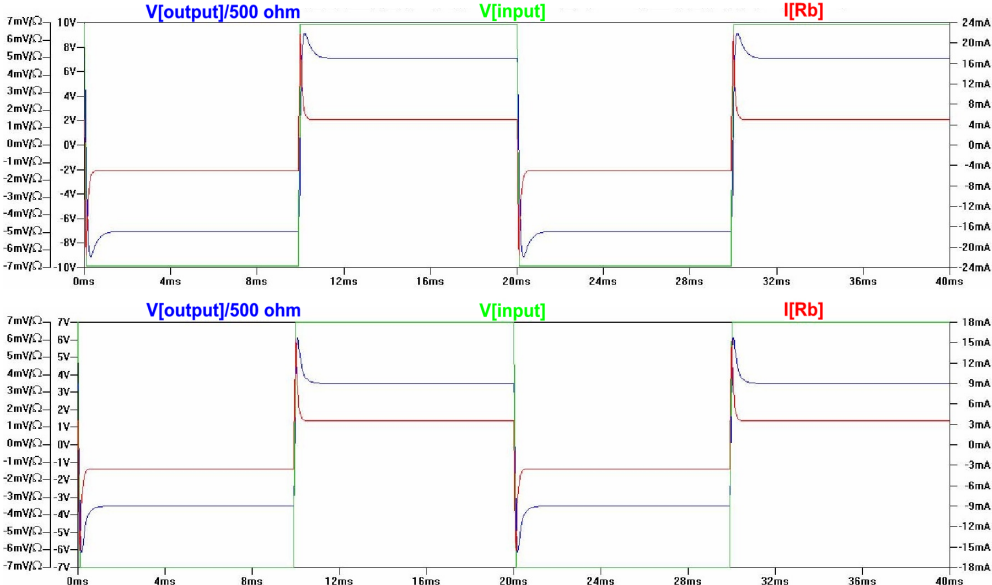

Figure 18. 20 ms (50 Hz) square wave response: startle-reaction circuit, upper; let-go circuit, lower.

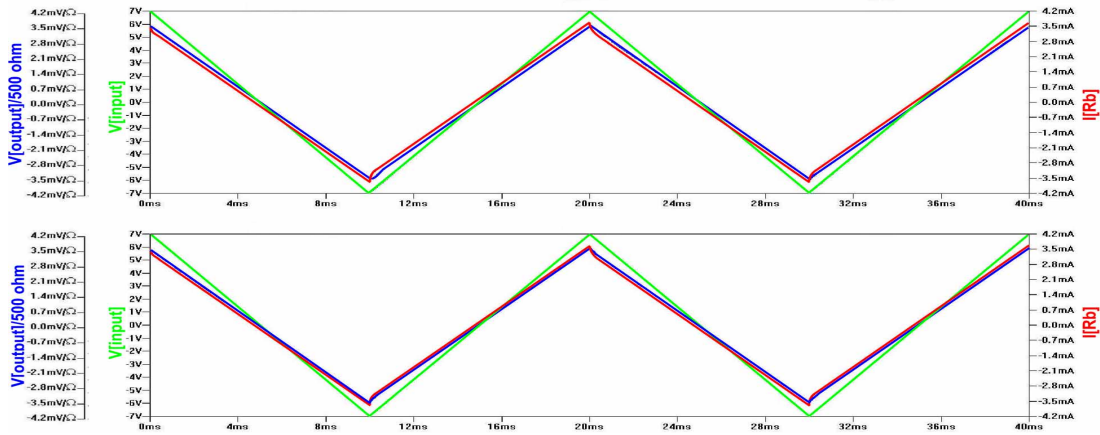

Figure 16. Triangular wave TC: startle-reaction circuit, upper; let-go circuit, lower.

Somewhat to our surprise, Figure 17 shows that there are considerable harmonics associated with the triangular waveform. The filter circuit component of the TC circuits properly acts on these high frequency components of each waveform.

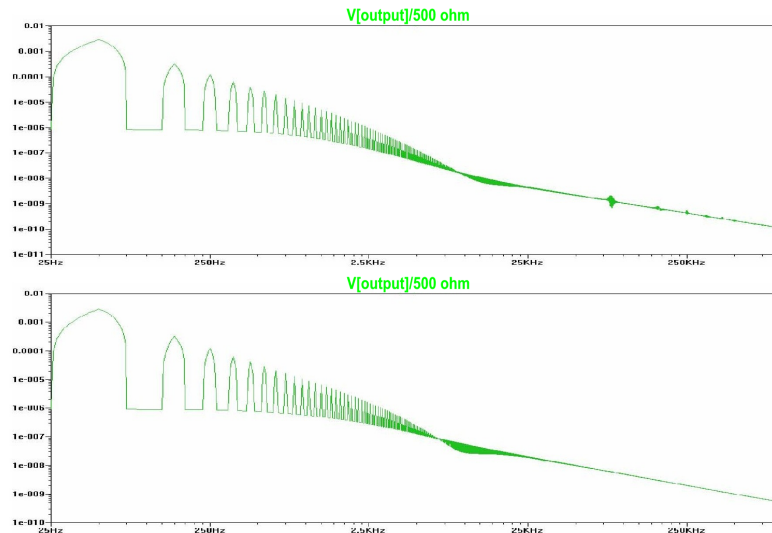

Figure 17. Triangular wave FFT: startle-reaction circuit, upper; let-go circuit, lower.

use 50 Hz for my analysis just because the period is 20ms, but it doesn't matter in this discussion.) The differences in the TC response (blue curve) between these s-r and l-g circuit response is easily distinguishable here. This square wave has a one percent rise time—a very short portion of the pulse.

There are enough high frequency components here that these circuits treat the applied voltages differently from each other. Although the rms values are about the same, the peak values are quite different. Because of these differences the peak/rms ratios are quite different. The peak values are the important measurement here because of our understanding that the body responds to peak currents, not RMS currents and the Peak, rms, and Peak/rms values are given in Table 8. The rms values are basically the same, but the peak values are quite different (> 37% higher).

Continued on Page 34

Table 8. 20 ms (50 Hz) square wave TC

Current	Peak	rms	Peak/rms ratio
s-r circuit TC = $I_{V(\text{output})/500 \Omega}$	6.39 mA	4.991 mA	1.280
l-g circuit TC = $I_{V(\text{output})/500 \Omega}$	8.758 mA	5.054 mA	1.733

Some high frequency differences can be seen in comparing two FFTs of the circuit response to the square wave as shown in Figure 19.

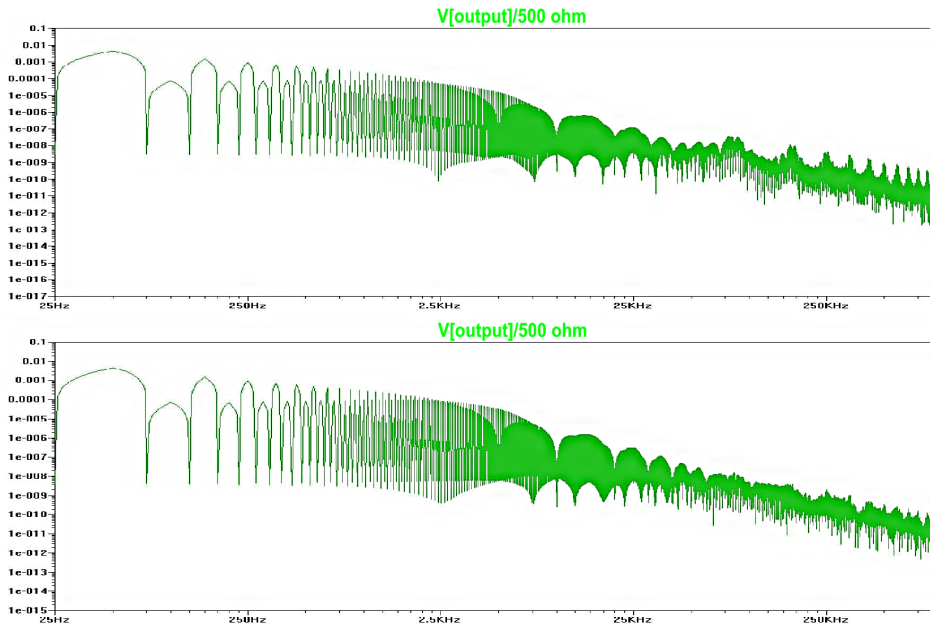

Figure 19. 20 ms (50 Hz) square wave FFT: startle-reaction circuit, upper; let-go circuit, lower.

Rectified sine wave

Figure 20 begins the discussion of rectification of line voltage which is an essential part of utilization of electric energy in equipment today.

Table 9 shows what we might begin to suspect, that the rms values are lower than our sinusoidal base case but the peak values are proportionally higher. The peak/rms ratio is greater than 2. The high frequency differences appear above 25 kHz as shown in Figure 21.

Table 9. Half-wave rectified line-frequency (60 Hz) sine wave TC

Current	Peak	rms	Peak/rms ratio
s-r circuit TC = $I_{V(\text{output})/500 \Omega}$	4.61 mA	2.264 mA	2.036
l-g circuit TC = $I_{V(\text{output})/500 \Omega}$	4.62 mA	2.265 mA	2.036

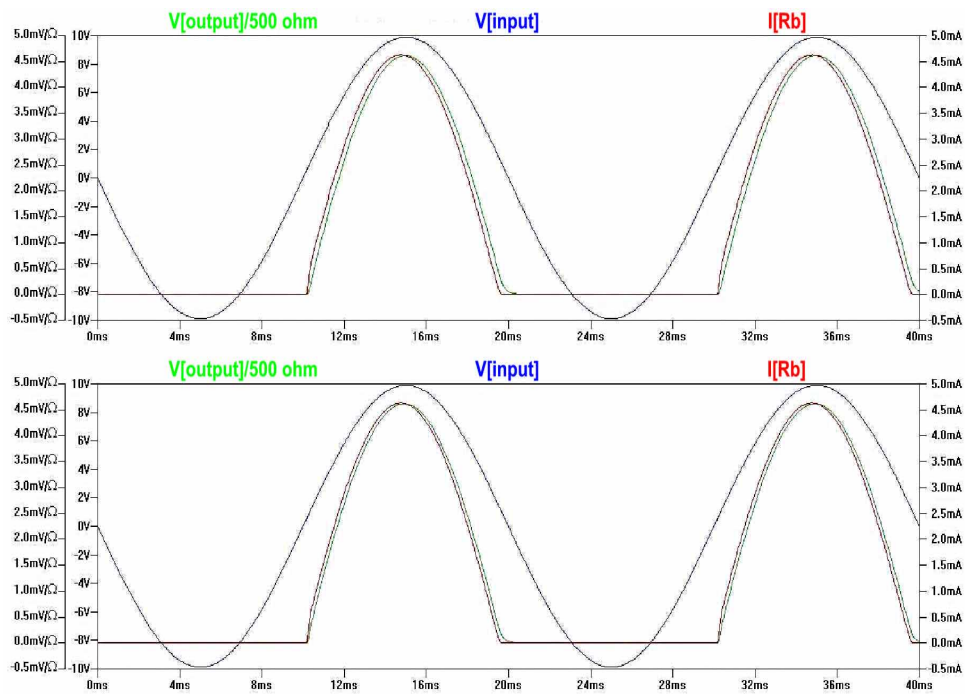

Figure 20. Half-wave rectified line-frequency (60 Hz) sine wave response: startle-reaction circuit, upper; let-go circuit, lower.

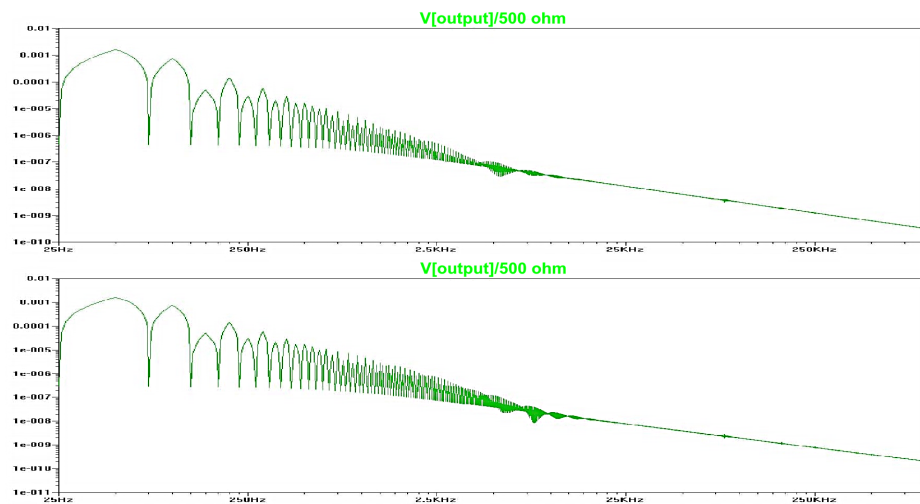

Figure 21. Half-wave rectified line-frequency (60 Hz) sine wave FFT: startle-reaction circuit, upper; let-go circuit, lower.

Table 10. 1 ms rise time pulse TC

Current	Peak	rms	Peak/rms ratio
s-r circuit TC = $I_{V(\text{output})/500 \Omega}$	8.319 mA	4.761 mA	1.747
l-g circuit TC = $I_{V(\text{output})/500 \Omega}$	8.917 mA	4.762 mA	1.873

1 ms square wave

Figure 22 shows calculated by this method of responses for 100 ms pulses having a 1 sec rep rate (within the heart cycle) and 1ms (1 percent) rise time.

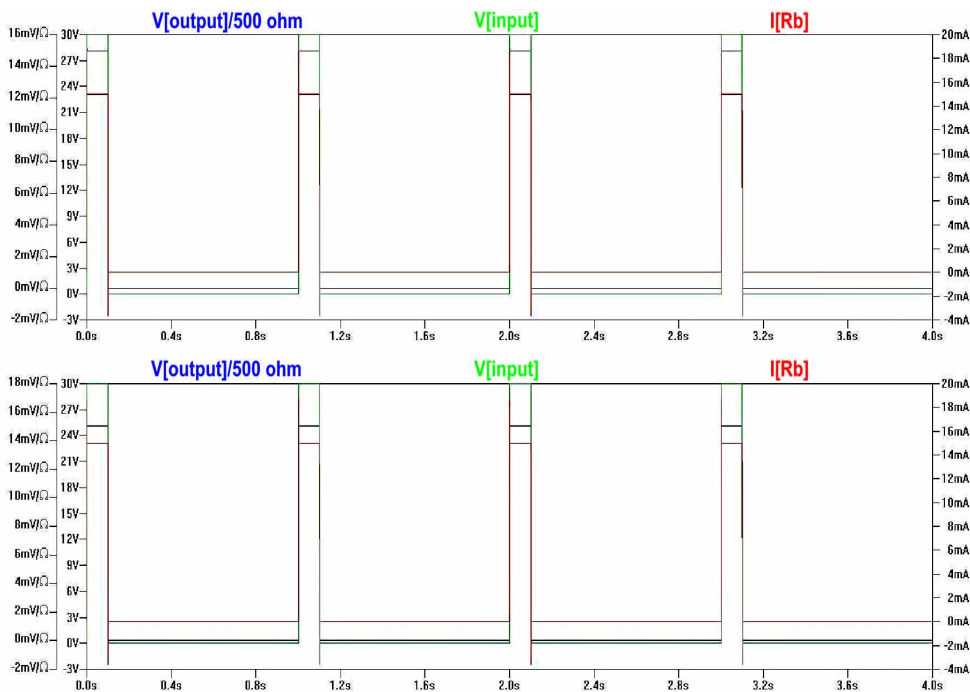

Figure 22. 1 ms rise time pulse response:
startle-reaction circuit, upper; let-go circuit, lower.

This calculation was performed to look for a TC below 14 mA peak, to prevent VF for the particulars of this case. With this rise time there is only a slight difference in the circuit responses between circuits, as shown in Table. The peak/rms ratio is not the square root of 2, however.

The higher frequency components show as slight differences here as seen in Figure 23.

As can be seen from Figure 24, at slow rise times the TC is about 7.5 mA in each case. At fast rise times, the TC is almost 10 mA for the s-r case and almost 14 mA for the l-g case. The control of rise time is the key to using impulse circuits in applications where TC approaches the limit.

Although the FFT waveforms seem to each other in Figure 25, the TC magnitude differs as we saw in Figure 24. Both the magnitude and the peak/rms ratio are different for a fast rise time when filtered by each TC circuit as shown in Table 11.

Limited current circuit analysis

Limited Current Circuit (LCC) evaluation portrayed in Figure 26 replicates a real world case. IEC 60950 allows access to circuits which will not be an electrical shock hazard. This specific waveform was submitted as a test case for analysis because of its characteristics.

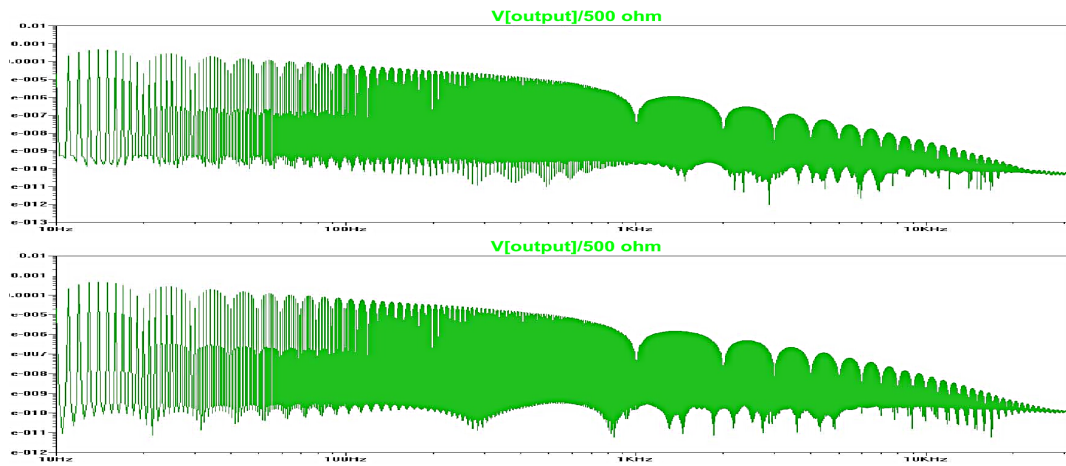

Figure 23. 1 ms rise time pulse FFT:
startle-reaction circuit, upper; let-go circuit, lower.

Examination of the LCC waveform from the s-r circuit shows the peculiar characteristic of being less than 3.5 mA rms but more than 5 mA peak (IEC 60950 limits); see Table 12. Again, reviewing this LCC waveform using the l-g circuit, the values are substantially larger and the peak/rms ratio is also larger.

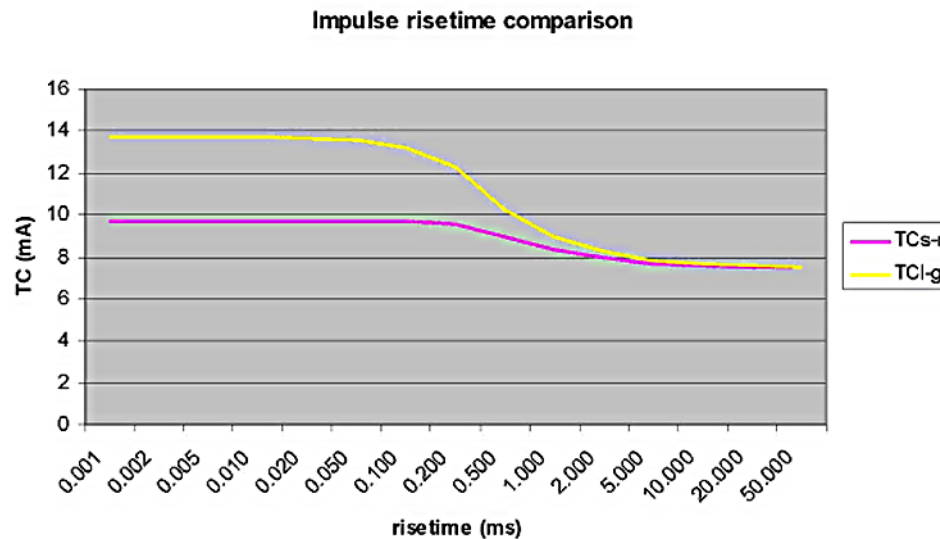

Figure 24. Impulse rise time comparison:
startle-reaction circuit and let-go circuit.

Compare the FFT's with each other (which appear quite similar and contain harmonics starting about 40kHz). This complex waveform cannot be evaluated by simply consulting the frequency factor curves. The use of peak measurement is the only way to evaluate this complex waveform.

Conclusions

This article compares the performance of the IEC 60990 eBurn, startle-reaction and let-go circuits against basic waveforms. This leads to a better understanding as to the action of TC waveforms and encourages the proper evaluation of TC waveforms in equipment¹.

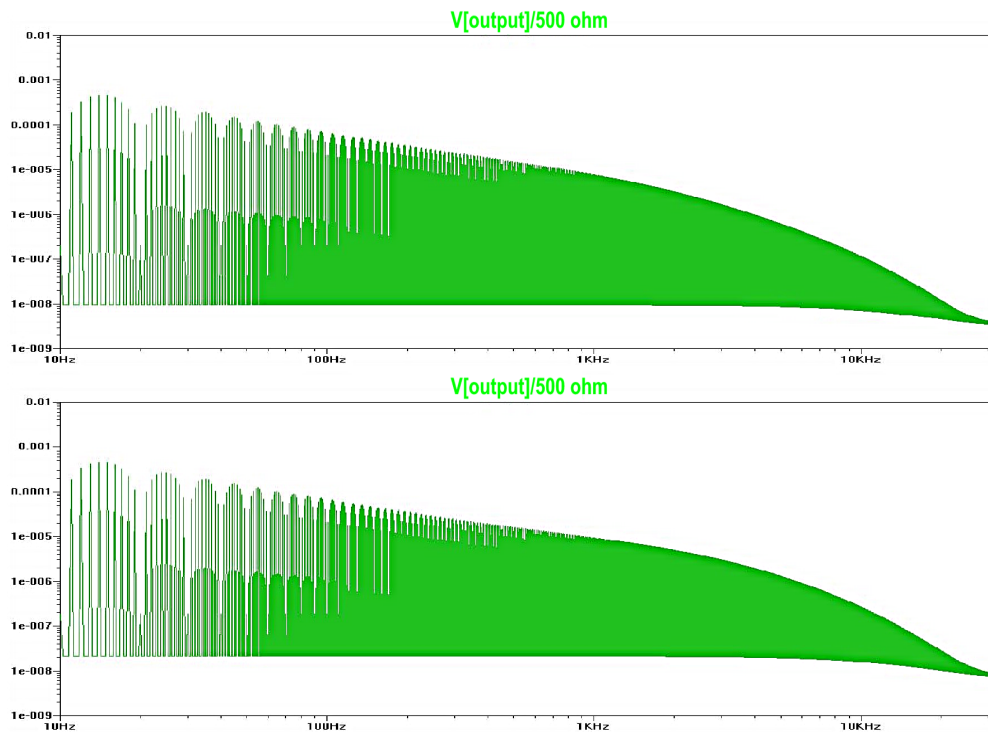

Figure 25. 0.01 ms rise time pulse FFT:
startle-reaction circuit, upper; let-go circuit, lower.

The simple waveforms shown here are not yet representative of the TC waveforms for modern equipment using mains voltage switching techniques. Switching electronics are used in switch mode power supplies (SMPS) and variable speed drives. This technology is spreading to many other types of equipment—commercial, industrial and household.

The principal conclusions are:

- Both the s-r and the l-g circuits serve in a similar way for evaluation of LF waveforms, they also properly accounting HF components.
- Use of the let-go circuit for values approaching the l-g limit curve requires a more conservative design to meet the limits.
- The most important conclusion is that peak measurements are needed for the s-r and l-g cases. These are specified in many standards but not uniformly applied today.

Touch Currents have become the low frequency counterpart to EMC currents—a residual of the design process and not clearly controlled.

Table 11. 0.01 ms rise time pulse TC

Current	Peak	rms	Peak/rms ratio
s-r circuit TC = $I_{V(\text{output})/500 \Omega}$	9.732 mA	4.746 mA	2.051
l-g circuit TC = $I_{V(\text{output})/500 \Omega}$	13.687 mA	4.749 mA	2.882

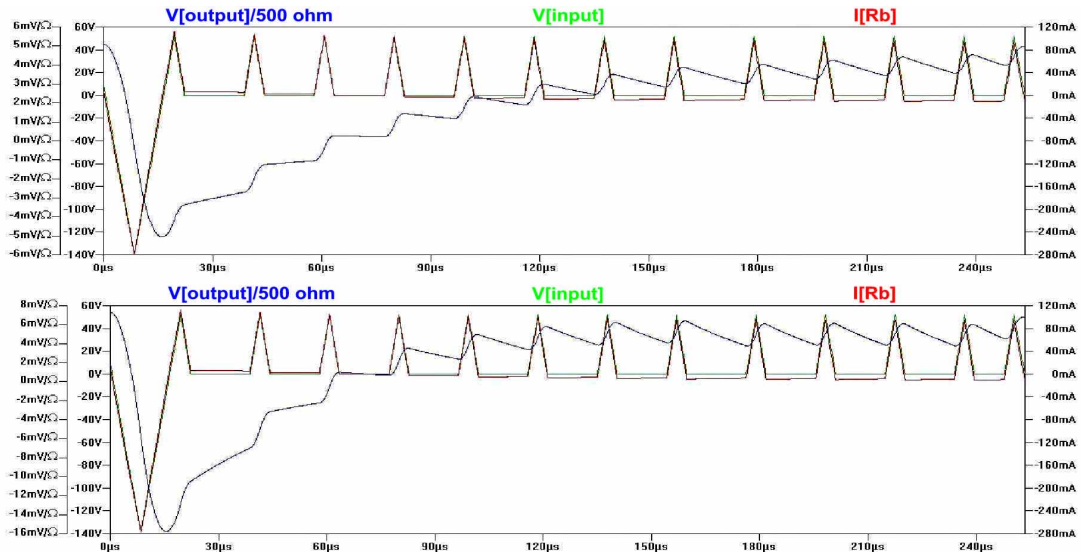

Figure 26. Limited current circuit:
startle-reaction circuit, upper; let-go circuit, lower.

Exploring further

How did we get to where we are today and what can we say about SMPS? Power supply manufacturers tout the performance of their modules in meeting the needed performance criteria for the applications they support.

Table 12. LCC TC comparison:
startle-reaction circuit and let-go circuit.

Current	Peak	rms	Peak/rms ratio
s-r circuit TC = $I_{V(\text{output})/500 \Omega}$	5.070 mA	3.090 mA	1.641
l-g circuit TC = $I_{V(\text{output})/500 \Omega}$	1.536 mA	5.645 mA	2.044

Note from the Figure 28 example, however, that the input current is never a fixed value, it oscillates over a small range (on the order of 1 A or so in this case) to maintain the output regulation needed.

This current oscillation is capacitively coupled to earth and contributes to the TC for the product. Many products use multiple dc-dc converters for the distribution of power in the product, and each of these contributes to the TC for the product in their own way. The measured TC will, of course, be composed of the sum of these sources. Note that both the output and the input show a continuous harmonic spectrum for this power supply as shown in Figure 29.

The measured TC for a pfcSMPS (pfc = power factor corrected, a major effort on the part of power supply manufacturers over the last 10 or more years to meet conducted emissions requirements) in a product is shown in Figure 30 (top waveform) along with the pfc input current waveform (bottom waveform).

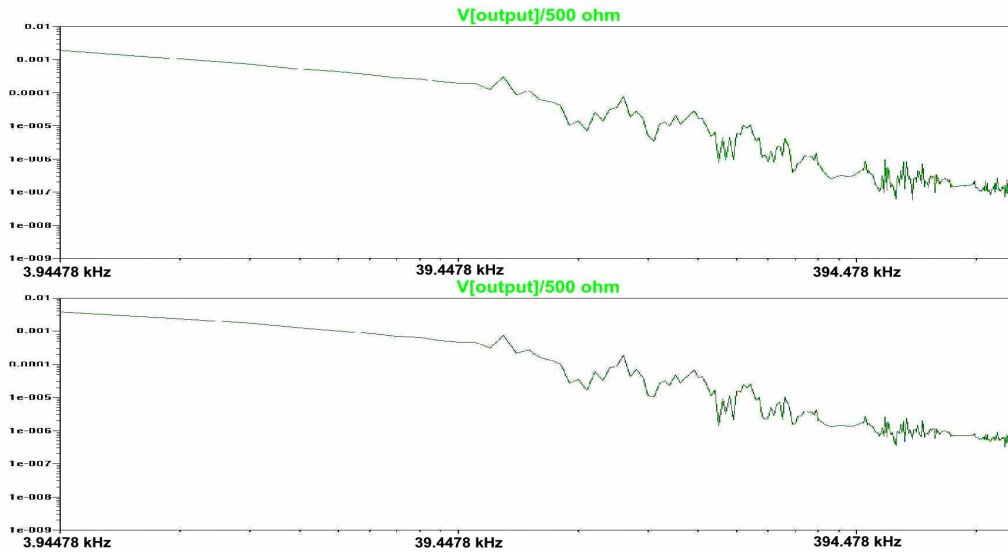

Figure 27. LLC circuit FFT:
startle-reaction circuit, upper; let-go circuit, lower.

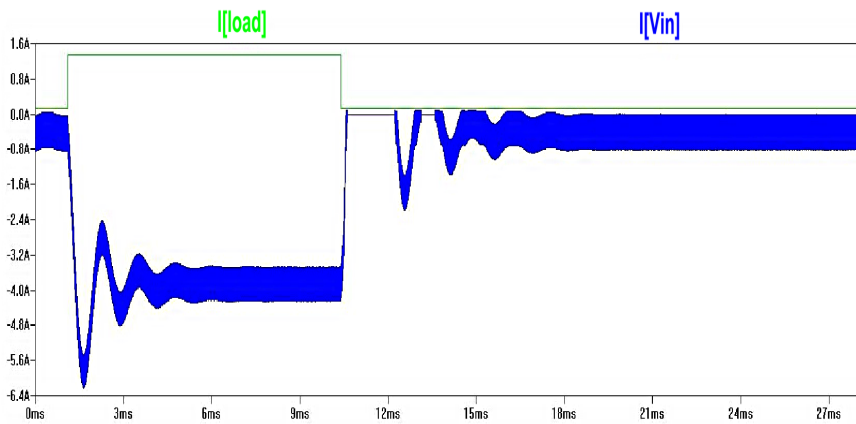

Figure 28. Prototype dc-dc power supply I/O currents.

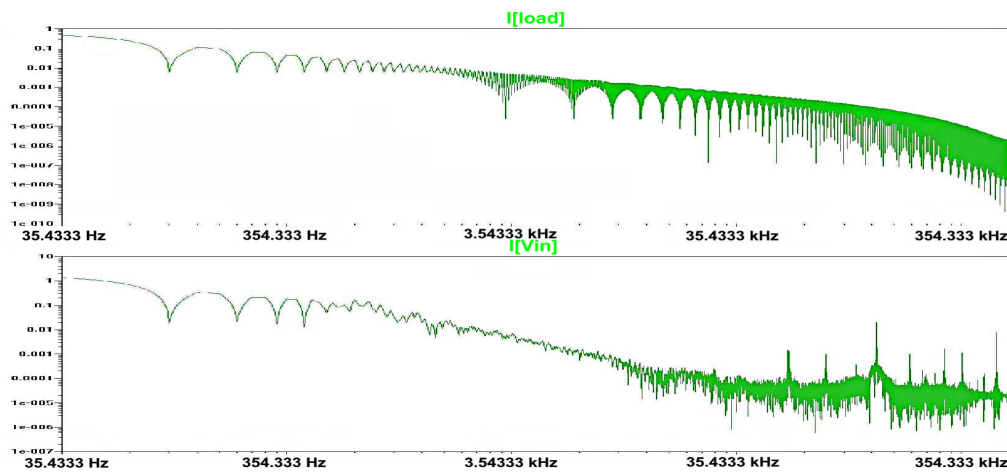

Figure 29. Prototype dc-dc converter I/O FFTs.

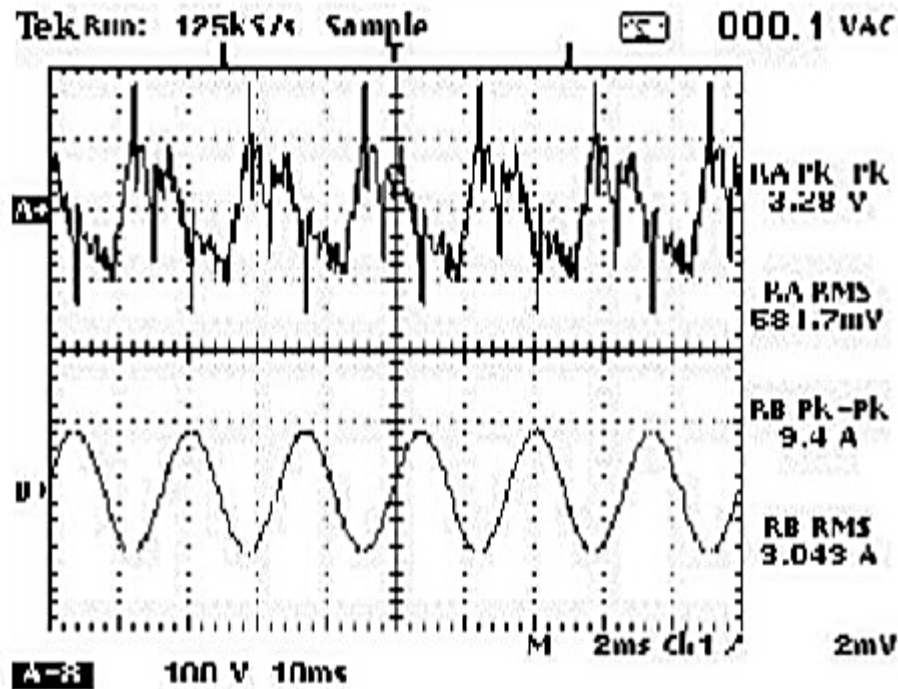

Figure 30. pfcSMPS TC waveform, upper; input current, lower.

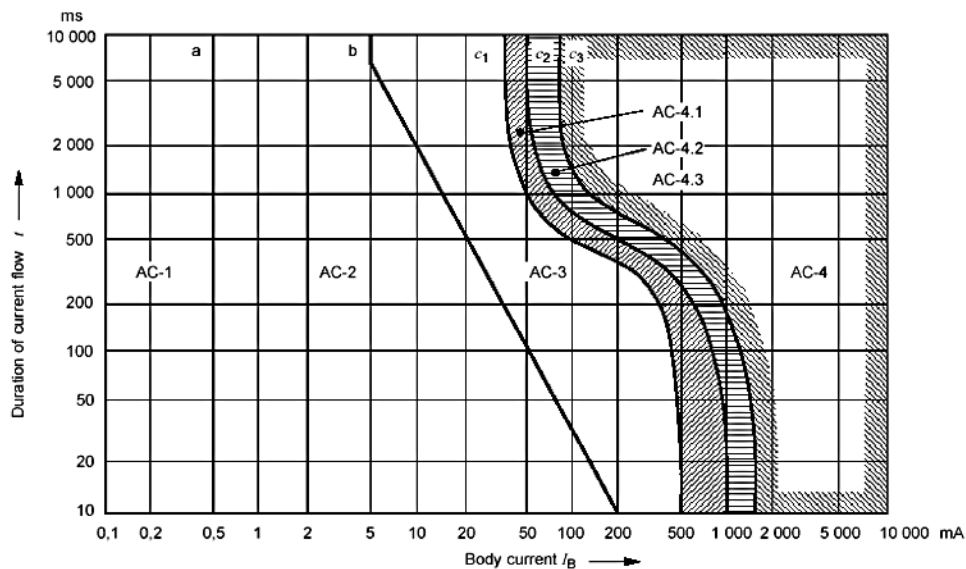

Figure 31. Measured frequency spectrum for pfcSMPS TC.

The measured harmonics for the pfcSMPS TC waveform shown in Figure 30 are presented in Figure 31. This oscilloscope analysis shows lots of harmonics near the fundamental as we've seen in many of the non-sinusoidal examples (triangular, square wave, rectified sine wave, and pulse). The oscilloscope analysis is limited to the first 50 harmonics (2.5–3 kHz); the SPICE analysis used in this paper includes these first 50 harmonics and then goes to higher frequencies.

Peter E. Perkins, PE is an independent product safety and regulatory consultant. He is a member of IEC TC64 (IEC 60479, IEC 61201); IEC TC 108 (IEC 60950 & prIEC62368); convenor of IEC TC 108/WG5 (IEC 60990); US/TAG-TC109 (IEC 60664); US/TAG-TC64 (IEC 60479, IEC 61201); US/TAG-TC66 (IEC 61010); and US/TAG-TC108 (IEC 60950). He can be reached at p.perkins@ieee.org or 503-452-1201.

Bibliography

- [1] IEC TS 60479-1, Ed. 4, 2005-07, *Effects of current on human beings and livestock – Part 1: General aspects*
- [2] IEC TS 60479-2, Ed. 3, 2007-05, *Effects of current on human beings and livestock – Part 2: Special aspects*
- [3] IEC 60990, Ed. 2, 1999-08, *Methods of measurement of touch current and protective conductor current*

(Footnotes)

¹ For a collection of TC waveforms for equipment see ‘Touch Current Comparison Data’ by PE Perkins, PE; at www.safetylink.com and search “Perkins.”

The Product Safety Engineering Newsletter is published quarterly during the last month of each calendar quarter. The following deadlines are necessary in order to meet that schedule.

Closing dates for submitted articles:

- 1Q issue: February 1
- 2Q issue: May 1
- 3Q issue: August 1
- 4Q issue: November 1

Closing dates for news items:

- 1Q issue: February 15
- 2Q issue: May 15
- 3Q issue: August 15
- 4Q issue: November 15

Closing dates for advertising:

- 1Q issue: February 15
- 2Q issue: May 15
- 3Q issue: August 15
- 4Q issue: November 15

Institutional Listings

We invite applications for Institutional Listings from firms interested in the product safety field. An Institutional Listing recognizes contributions to support publication of the IEEE Product Safety Engineering Newsletter. To place ad with us, please see :

<http://www.ieee.org/ieeemedia>

Click here to go to the IEEE PSES advertising pdf

The Product Safety Engineering Society will accept advertisements for employment and place looking for work ads on our web page. Please contact Dan Roman for details at dan.roman@ieee.org .

The
Product
Safety
Engineering
Newsletter

Gary Weidner
GW Technical Services Inc.
2175 Clarke Drive
Dubuque, IA 52001-4125

CHANGE SERVICE REQUESTED