

The

Product Safety Newsletter



EMC SOCIETY

Vol. 6, No. 6 December, 1993

What's Inside

Chairman's Message	1
Officers of the PSTC's	2
Letters to the Editor	3
Area Activities	4
Technically Speaking	5
ECMA Generic Safety Standard Activity .	6
Hi-Pot Leakage Current	7
Safety Net--News from the Internet	8
Executing Product Safety Functions	9
Institutional Listings	22

Chairman's Message



by Brian Claes

As I promised last issue, I want to share in greater detail some of the decisions made at this year's Product Safety Technical committee (TC-8) annual meeting.

Charter Revisited

Of great significance is the widespread support for broadening out formal statement of scope. First, let me say that any changes to our charter must be approved by the EMC Society Board. However, it is important that we have discussion about the proposed changes before making our formal recommendation. While some may take a "who cares?" attitude about wording changes in charters, I believe they reflect profound ongoing changes in our focus, that these changes will have a marked impact on what we do and that acknowledging and embracing these changes will accelerate our growth.

Many of you may not be acquainted with our statement of scope, so it is reprinted here with the proposed changes (additions are in *italics*, deletions are **strike through**):

Continued on page 20

The Product Safety Newsletter

The *Product Safety Newsletter* is published bimonthly by the Product Safety Technical Committee of the IEEE EMC Society. No part of this newsletter may be reproduced without written permission of the authors. All rights to the articles remain with the authors.

Opinions expressed in this newsletter are those of the authors and do not necessarily represent the opinions of the Technical Committee or its members. Indeed, there may be and often are substantial disagreements with some of the opinions expressed by the authors.

Subscriptions are free and may be obtained by contacting "Subscriptions", below.

Central Committee

Chairman:	Brian Claes	(510) 659 6574 (510) 659 6852 (fax)	
Vice Chair:	Richard Pescatore	(408) 447 6607	Pescatore@cup.hp.com
Sec./Tres.:	John McBain	(415) 919 8426 (415) 919 8504 (fax)	john_mc Bain@hp-sunnyvale-om3.om.hp.com
Symposium:	Mark Montrose	(408) 247 5715	

Local Groups

Chairman:	John Allen	CHICAGO (708) 238 0188	
	Richard Georgerian	COLORADO (303) 417 7537	
Chairman/Sec.:	Charlie Bayhi	So CAL/ORANGE COUNTY (714) 367 0919	
Chairman/Sec-Tres.:	Scott Varner	PACIFIC NORTHWEST (PORTLAND) (503) 656 8841	4772949@mcimail.com
	Dave Lorusso	NORTHEAST (508) 435 1000 x7518	lorusso@emc.com
Chairman:	Murlin Marks	SANTA CLARA VALLEY (408) 985 2400 X2353	743141.3433@compuserve.com
Chairman:	Walt Hart	SEATTLE (206) 356 5177	walthart@tc.fluke.com
Chair	Vic Baldwin	TEXAS (CENTRAL) (512) 990 6145	

Newsletter Committee

Editor	Roger Volgstadt	(408) 285 2553 (fax)	volsgstadt_roger@tandem.com
Subscriptions	Dave McChesney	(408) 296 3256 (fax)	
Institutional Listings	Ron Baugh	(503) 691 7568 (fax)	ron.baugh@sentrol.com
News & Notes	John Rolleston	(614) 438 4355 (fax)	jhrolles@freenet.columbus.oh.us
Activities Editor	Kevin Ravo	(408) 296 3256 (fax)	kravo@aol.com
Page Layout	Ken Warwick	(408) 974 0113 (fax)	warwick2@applelink.apple.com

How to Avoid Being Laid Off

[The following article is reprinted with permission from Scripps Howard News Service. Regardless of your reasons, here are some good ideas that will enhance your PROFESSIONALISM. -Ed]

by Paula Ancona

It's got to end soon, right? Those relentless waves of downsizing and staff slashing that have pounded your job security?

Maybe not, says consultant and author Robert Barner. "We are going to see two things in 1994," predicts Barner, vice president of Parry Consulting in Tequesta, Fla. "One is the improvement of the economy. And the strange thing is, we are still going to see a very bad employment picture."

'Lifeboat strategies'

The goal for many workers today is to fortify their value as employees and hang on to their jobs.

Barner has written a book about that tactic. "Lifeboat Strategies.- How to Keep Your Career Above Water During Tough Times Or Any Time" (Amacom, 1993) that will be available in November.

Here are ideas from Barner; James Cotham's book, "Career Shock" (Berkley Books, 1992); and other sources.

- Look for new skills, experiences and responsibilities, even if you've been in your job a long time or are considered an expert. If your resume doesn't show three major accomplishments or new skills in the last six months you've been lax. Be able to do more than one job at your company.

Consider your reputation

- Develop a reputation as a helpful, resourceful coworker. Do unsolicited favors for coworkers, even if it causes you some inconvenience, suggests Marilyn Moats Kennedy in her newsletter, "Kennedy's Career Strategist." Ask the people you work with how you could make their jobs easier.
- Analyze your performance by pretending to apply for your own job. What qualities would your boss seek? How could you become a better candidate?
- Avoid what Barner calls "image lag"-an outdated notion about who you are, what you do and what you're good at. (Example: You say you're inept with computers but actually you've developed useful word-processing skills.)
- Get accurate feedback on your current accomplishments and abilities from people outside of your immediate work group. Measure yourself against the best in your field, not just in your company.
- Identify the "hot buttons" of the key players in your organization (cost containment, quality improvement). Find ways to tie your work to those areas.
- Keep a success folder or journal, Barner suggests. Update it weekly with details about major projects and accomplishments. Use it to keep your resume updated. Present highlights from it to your boss.
- Be extra sensitive about wasting the company's money and time.

Paula Ancona, former staff-development director at The Albuquerque Tribune, has been writing about workplaces since 1987 □

Technically Speaking



by Richard Nute
Copyright 1993

THE MYTH OF ACCESSIBILITY

Almost every safety standard has requirements addressing the accessibility of certain parts. These take either of two forms: Hazardous parts shall not be accessible, or Accessible parts shall not be hazardous.

The single most common device used to fulfill these two requirements is the enclosure. Enclosing hazardous parts within an enclosure renders those parts inaccessible.

Here are the requirements restated as “fulfillments:”
Enclosed hazardous parts are not accessible,
or
Enclosure accessible parts are not hazardous.

Let’s examine in detail how the enclosure makes a product safe. How does making the parts inaccessible make a product safe? The obvious answer is: We cannot touch hazardous parts.

But, if we remove the enclosure and operate the product then we have:
Hazardous parts which are accessible,
and
Accessible parts which are hazardous.

Some of us do this every day, yet we do not incur injury. Clearly, the enclosure does not provide a safety function as products can be operated safely without the enclosure. When there is no enclosure, what mechanism provides the protection against injury?

‘The obvious answer is: We do not incur injury because we discern which accessible parts are hazardous and then, voluntarily, choose to not touch those accessible hazardous parts.

Note that the requirement for injury is that the part must be touched.

If the part is not touched, then no injury occurs. This implies that there is some “thing” interposed between the body part and the hazardous part that provides safety. What is this “thing”?

Let’s examine the situation of the enclosure as protection against electric shock. We don’t have everyday life household examples of hazardous electrical en-

Continued on page 17

News and Notes

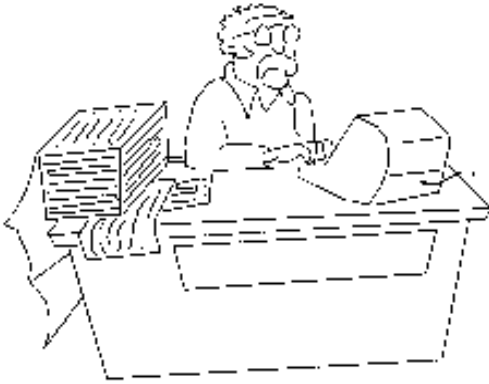

by Dave Edmunds
fax: (716) 422-6449

Ergonomic Fixes

The September 1993 issue of *Professional Safety* has an article "Evaluation of Quick Fix Solution to Cumulative trauma Hazards". This article overviews those quick fixes such as abdomen/back belts, wrist straps/supports, supports and cushions, and discusses their efficiency.

New Address

The DHHS through the CDRH (Center for Devices and Radiological Health) administrates manufacture of Laser and TV (including work stations & monitors). They have a new address:

CDRH, Office of Compliance
2098 Gaither Road
Rockville, MD 20850

The annual report goes to RIRB/OC, HFZ-300, all other correspondence FPRC, BFZ-312. Their new phone number is (301) 594-4654, fax (301) 594-4672.

950 Index

ECMA (European Computer Manufacturer's Association) has an alphabetical reference Index to IEC950 second edition including Amendment I and 2. Copies may be obtained from ECMA, 114 Rue du Rhon, CH1204, Geneva Switzerland.

Connector Cords

Appliance Manufacture, September 1993, has an interesting article entitled "Connectors and Cords". A second article "Protective Devices on Cords" briefly describes GFI, GFIC, IDCI and ALCI differences in protection of power cords to provide an extra level of safety.

DEMKO in US

DEMKO has opened an office in Melville NY and has advertised the capability to get world wide acceptance with a CB certificate. For funber information contact S. Fabian

DEMKO Product Services
Expressway Executive Center
48 S. Service Rd. - Suite 100
Melville, NY 11747

Phone: (516) 847-0037
Fax: (516) 847-0410.

VDE Annual Component Index

Euro Port, P.O. Box 243, Manchester, MA 01944, has announced that the 1993 edition of the VDE Annual Component directory is available. Contact Mrs. Renate Paster-Pusch (508) 526-1687 for price and a listing of

Continued on page 20

Area Activities



by John Reynolds
381 Los Pinos Way
San Jose, CA 95123-5118
fax: 415-962-9439
e-Mail:REYNOLDS@ESD.SGI.COM

Portland/Seattle Area Activities

The September meeting was held at the Portland General Electric Co. on the 21st at 7:30PM in Beaverton, OR. The speaker was Mr. Richard Nute of Hewlett Packard, Topic: "Accessibility as it relates to Product Safety". The October meeting featured Mr. Joe Patterson of JV Patterson Consultants, Topic: FDA/Radiological Health requirements. A dinner and social were held at the Cattle Company Restaurant at 5:30PM.

Santa Clara Valley Activities

The Santa Clara Valley group met at Tandem Computers in Cupertino on the 28 of September. The meeting started at 5:30PM with dinner and social. Brian Claes,

National Chairman, gave a presentation on the new direction for the technical committee. He outlined a broader scope for the group, beyond just product safety, beyond just electrical safety. This brought forth some interesting discussion and de-bate. Rather that give all the details I will let Brian tell you himself (see the Chairman's Message). But a rethinking of our purpose and the types of safety engineering we want to address should contribute to our growth. Next Merlin Marks went over the next years schedule of speakers, and then there was a. discussion of how to generate more interest and participation in writing papers.

Chicago Group

We need to bear from you. How is it going? We hope you are making progress towards getting the group active again. Best wishes!

Southern California Group

The Southern California Group met on Tuesday September 14th at FileNet in Costa Mesa. The meeting consisted of an open workshop, covering a variety of subjects. Members in attendance shared information on changes to standards, upcoming regulations, etc. Other items covered were the Christmas Committee, Green PC's, Job Openings, 1994 Dues/ Membership Renewal, the next months meeting, and Units of Measure, Conversions and Equations. Paul Herrick has put together a very helpful sheet of conversions between metric and English units, covering all the units in IEC950, UL1950 and CSA950. For a copy please contact Deborah Tinsley, P.E., Secretary /Treasurer, at Beckman Instruments, Inc.

Continued on page 13

Spacings, Creepage and Clearances



by Paul W. Hill & Associates
© 1990

[We are grateful to the author for providing another installment condensed from his book "Product Safety As A Design Parameter", 2nd Edition, 1990. The tell is a registered copyright of Paul W. Hill & Associates, Inc., and is reproduced with permission. We hope to be able to provide further sections from the book in future issues of PSN. Details about the purchase of the book may be obtained by calling (407) 368 2538 - Editor]

The spatial separation of conductors is a practical technique for providing necessary electrical insulation in circuits. Consider the utility company power lines. The spatial separation of the lines in the air prevents conductors of different polarity or voltage level from making electrical contact. The insulators holding the power lines electrically insulates the conductors from the pole or supporting structure. The glass or ceramic is ridged or grooved to provide a long

creepage path over its surface.

These same electrical insulation techniques used for a power line appear in electrical circuits on a smaller scale. Spatial separation in air is a form of spacing called CLEARANCE. The insulator and its grooves or ridges is a form of CREEPAGE to reduce tracking and arcing. In some standards creepage is referred to as "distance over the surface".

The scaling factor between a power line and electronic circuitry is purely a matter of the voltages involved. Clearly, the lower the voltages in the power lines the smaller the acceptable spacing of the conductors, the smaller the insulators and the shorter the creepage path over insulating surfaces.

1. Function of Conductor Spacings.

The most elemental reason for conductor spacings is the proper functioning of the circuit. Conductors of different polarity or different voltage levels must not be in electrical contact with one another if the circuit is to function properly. This separation distance need not be great in most cases, and if this were the only consideration conductor separations would be only a small fraction of the values given in standards. As mentioned earlier, the operational requirements are not the most demanding property of the insulation system, rather, it is the prevention of electric shock. It is this requirement of the insulation system that makes conductor spacings considerably larger than that required for acceptable circuit functioning.

A second consideration in conductor spacing is compensation for decay of electrical insulation

Continued on page 14

Capacitor Discharge and Energy Hazard

by Lal Bahm P. Eng.
Canadian Standards Association

Let us examine capacitor discharge and energy **hazard** requirements as given in IEC Publication 950/CSA Standard C22.2 No 950.

(a) Sub-clause 2.8 requires that within 2 seconds after opening or removing covers and doors etc., circuit voltages shall be reduced to 42.4V peak or 60V dc or less and the energy level reduced to less than 20J or 240VA. During the cover removal process, compliance is checked by means of an articulate test finger (Fig 19 in draft of the second edition of IEC Publication 9501 Fig 10 in CSA Standard C22.2 No 950).

(b) Sub-clause 2.1.10 stipulates that the stored charge on capacitors connected to the mains circuit shall not present a shock hazard at accessible points (e.g. attachment plug blades) with the switch in either the “on” or “off” position, after disconnection from the supply. If the total circuit capacitance is 0.1mF or less, equipment is considered to comply with the requirement without performing the test.

If the capacitance exceeds 0.1mF a discharge means shall be provided so that the voltage discharge time constant of the circuit does not exceed 1 second for pluggable equipment Type A. In Canada and the USA, equipment provided with a 15A or 20A non industrial non-locking type attachment plug is considered to be pluggable equipment, Type A. For permanently connected equipment and pluggable equipment Type B, the voltage discharge time constant shall not exceed 10 sec. Pluggable equipment, Type B, is equipment provided with other than a non-industrial type attachment

plug.

The discharge time constant is determined by the total effective capacitance and resistance in the circuit. In many cases, the effective capacitance and resistance are difficult to determine.

The voltage-decay measurement method may be used to measure the time in which the voltage decays to 37% of its original value which is defined as 1 time constant.

If we take an example where the effective capacitance is 0.1mF and shunt resistance is 10 megohms (which may be the approximate effective resistance if no bleeder is provided in the unit), then the time constant = $(0.1 \times 101) \times (10 \times 101)$.

For a unit of equipment rated 240V, the max voltage can be 250V - depending on the actual voltage supplied by the utility. If the unit is disconnected from the power supply at the peak of the voltage sine wave, then the initial voltage of the effective capacitance = $250 \times 1.414 = 353.5V$ dc.

Using the voltage-decay method, the voltage after 1 time constant (or 1 second) = $353.5 \times 0.37 = 130.8V$ dc.

Voltage after 2 time constants (or 2 seconds) = $130.8 \times (2 \times 0.37) = 48.39V$ dc which is within the safe limits.

If we look closely at Sub-clause 2.8, there seems to be two separate requirements. The sub-clause would require that 2 seconds after the operation of any inter-

IEC 990 Measurement Methods of Touch Current

Measurement Methods of Touch Current and Protective Conductor Current

a review by Peter E. Perkins, PE

Copyright (c) 1992 Peter E. Perkins, PE All Rights Reserved

As with most safety standards systems, the IEC has not had a uniform method for specifying conditions and methods of measurement of leakage Current in equipment. Broad adoption of the complete requirements laid out in IEC 990 will continue the process of harmonizing requirements within the IEC system.

Based on our experience to date, equipment communities will slowly adopt this set of comprehensive requirements to replace the myriad of requirements currently used in product safety standards.

As with any engineering topic, the conditions for measurement, the measuring equipment and the test conditions must be clearly laid out to ensure consistent and repeatable measurements. The criteria laid out in this IEC report clearly defines the conditions for measurement of any equipment in such a way that repeatable results are obtained by any laboratory and that the results of repeated testing in separate labs will show the same result.

Inadequate consideration to the details of measurement and the measurement setup will result in poor results.

The key features of this standard are:

1. IEC 990 deals with the procedure and equipment to comprehensively measure leakage current. A single body response model, appropri-

ately weighted for frequency, is used to replace several models commonly used in the past. The major technical improvement contained is the move to use peak value measurements which correctly indicate the hazard levels for either AC or DC currents.

2. IEC 990 provides equipment committees with information to specify conditions of operation under which these leakage currents will be measured. There is a wide diversity of conditions of operation specified in product standards and these will be rationalized, i.e. brought to a single set of conditions, by this work.
3. IEC 990 specifies the test procedure which is to be used to determine the worst case current available. Detailing the combinations of conditions for the test setup and the procedure will lead to more clearly specifying the worst case condition.
4. IEC 990 defines the device characteristics for the measuring device. Using equipment that is inadequate for the measurement will give erroneous readings and a false sense of security. Ongoing work will further clarify these equipment requirements.
5. IEC990 carefully defines the domain under which these techniques will provide acceptable results. The effects of either AC or DC currents are well known; the effects of combined AC and DC are not well understood and so are outside the conditions considered here.

This is a review of the IEC Report on measuring Touch

Current and Protective Conductor Current, IEC 990. 'This Report, published in 1990, deals with the procedure and equipment to comprehensively measure leakage current; it also provides guidance to equipment committees to direct conditions under which to choose current limits.

This assignment was made by IEC ACOS (Advisory Committee On Safety) to bring about harmonized, rationalized requirements for leakage current within the IEC standards system. This set of requirements are a Pilot document under the IEC system and these basic requirements apply broadly across all IEC standards.

Although the existent methods have been around for some time, differences in the test circuit used, the conditions for testing (to get to the worst case operating mode of the equipment) and adequately testing for normal and fault conditions on any electrical system worldwide were not always common between labs and test engineers. The equipment must still be safe under the worst case conditions expected and the tests must confirm that. 'This work further standardizes the test regimen to achieve these results.

'This fundamental, basic information is important to the engineering community, both designers and product safety engineers, who are responsible for designing and manufacturing safe products. The fundamental protection against electric shock is primarily provided in the initial design of the product. Manufacturing errors may creep into the product but these can be screened by routine safety tests on the output of the manufacturing line. An understanding of the fundamentals of protection from known harms and designing equipment to mitigate that harm to users is a prime role of design.

IEC 990 carefully lays out the conditions for measurement for several harmful effects - electric bum, percep-

tion reaction and let-go situations. These conditions are the principle issues that need to be dealt with, assuming ventricular fibrillation is never allowed condition.

'This paper is a summarizing discussion of the IEC document, to introduce the topic and results to the larger technical community not familiar with the IEC standards system not the information available from it. North American standards relating to electric shock protection (e.g. ANSI C101, *Protection from Electric Shock*) have been historically written somewhat independently of the information available from the international community, as laid out in relevant IEC documents. It is hoped that continued joint efforts will bring about further harmonization of measurement techniques.

The term leakage current is now rendered obsolescent because of the many, varied uses of that term and two new terms Touch Current and Protective Conductor Current are used to replace it. These new terms are now specifically defined for this application to rid us of any greater confusion continuing.

It's personally satisfying to be able to present this comprehensive, rationalized system for protection as outlined in the series of IEC standards - MC 364-4, IEC 479 and IEC 990. This inclusive set, covered in related reviews, describes the acceptable systems for protection, effects of current on the body and methods of measurement of this current.

The standard further clarifies several difficult points. One significant issue is the interconnection of equipment which has been an indeterminate issue. IEC 990 defines equipment and equipments for purpose of measurement.

This is intended to reduce the confusion as to what is

intended to be measured. The standard illustrates how all equipment drawing power from a single supply cord must be treated as a single unit.

This latest information completes the IEC trilogy of standards on electric shock; IEC 364-4-411 *Systems of Protection against Electric Shock*, IEC 479, *Effects of*

Electric Current on the Human Body, and lastly, IEC 990, *Measurement of Touch Current and Protective Conductor Current*. Understanding these basics provides a comprehensive set of requirements for use. Take the time to read through the standards to get the full detail on these means of protection from electric shock in electrical equipment.

Capacitor Discharge

Continued From page 8

lock switch or disconnect in a device, or employment of the time constant method or less, the voltage present at user accessible terminals or conductors must decay to 42.4V or less. In addition, the energy level shall be less than 20J.

The requirement of Sub-clause 2.8 does not mean an

energy level of 20J at 42.4V peak of 60V dc or less. - These two parameters are separate and independent of each other. The energy level of 20J can be present at any voltage level including 5V SELV (as an example). In this case, there will not be any shock hazard, but an energy hazard may still exist. High energy circuits may cause burns due to arcing, ejection of molten metal or heating of metal parts in contact with the body (e.g. ring worn on a finger). The term "Energy" hazard may be a misnomer and should perhaps be called a

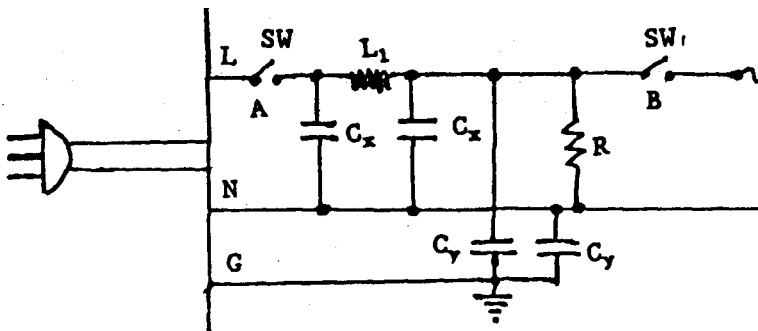

FIG 1

burn hazard).

Shock Hazard

The first part of Sub-clause 2.8 applies to primary and other shock hazard areas which may be accessible to the user. Examples are:

- i. Attachment plug blades.
- ii. Bare fuse and lamp terminals in copiers or printers which are often accessible upon opening a front access door.
- iii. Capacitors commonly used in the primary EMI filter circuit of most cord connected products are usually of such a value that limits of the stored energy

level to less than 1J. In this case, testing is only required to determine the voltage after 2 seconds. Alternatively, the time constant method may be used. In order to store 20J of energy, an equivalent line shunt capacitance of 1280mF is necessary for a 125V supply, or 320mF for a 250V supply ($E = 0.5CV^2$). Capacitors of these values are not commonly used across accessible terminals (line-to-line or line-to-ground) and so this arrangement will seldom be used.

The test usually conducted to confirm there is no shock hazard is described below.

If the switch of a unit is at location A (see Figure 1), the test is not required since the capacitor will discharge

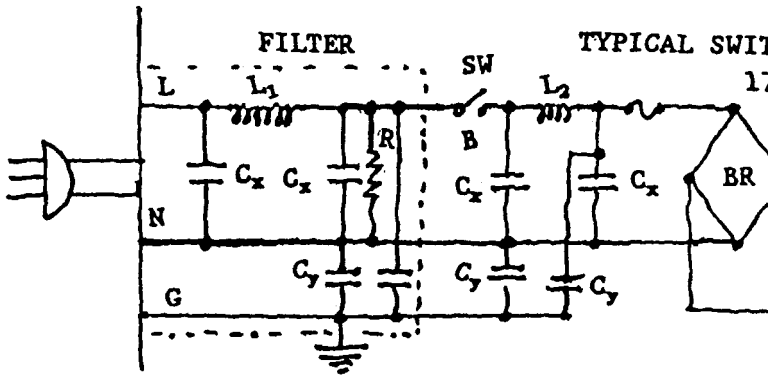

FIG 2

through the low impedance of the transformer when the switch is closed. With the switch open, the capacitor has no connection to the blades of the plug.

If the switch is at location B of Figure 1, the test is required. The test shall be conducted with the switch in the open position. The separate bleeder resistor “R” may or may not be present.

In the case of the circuit illustrated in Figure 2, the test must be conducted with the switch (shown at location B) in both the “on” and “off” positions. A bleeder resistor “R” may or may not be present. The capacitors cannot fully discharge through the rectifier diodes and transformer circuit since the diodes stop conducting as soon as the voltage level on the supply side of the rectifier falls below the voltage present at the storage capacitor (“CF”) terminals, after the unit is disconnected from the supply.

Energy Hazard

The second requirement of Sub-clause 2.8 applies to the secondary circuits of high current power supplies (eg. 5V, 1000A supplies) that become accessible to the user after opening an interlocked door or cover. In this case the energy level must decay to a safe level after the interlock switch disconnects the circuit from the supply. The effective capacitance value has to be very Urge to produce 20J of energy.

Further many power supplies are certified as components, to be evaluated in the end usage of the product. If high energy outputs have to be accessible during replacement or maintenance by the user then bleeder resistors shall be provided so that stored energy discharges to a see level from the time of disconnection fill they become accessible.

Energy = Power x time = V x I x time

As long as the circuit is opened and discharged within a short time period (as is normally done in fail safe systems so that the energy level is within limits), access to outputs may be acceptable.

In addition to the above CSA Standard C22.2 No 950 anticipates that some large capacitors at high voltages inside the enclosure may take longer to discharge to a safe level. Only service person will have access to such capacitors which will be accessible after the use of a tool. Equipment in such cases shall be marked with a clear instruction specifying time required for a safe discharge.

Area Activities

Continued From page 6

Tel: 714/773-7977, Fax: 714/773-8106

Colorado Area Group

There is interest in starting a new group in the Denver, Colorado area .I just received a call from Mr. Andrew Doering of TUV Product Service who said a preliminary telephone survey indicated some interest within the local manufacturing community. If you would like to be part of this new group please contact Mr. Doering at the following address / Tel:

TUV Product Service
5541 Central Ave.
Boulder, CO 80301
Tel: (303) 449-4165
Fax: (303) 449-3004

Let me bear from you. We all can benefit from your experiences.

Bye for now!

Spacings

Continued From page 7

properties over time. One such factor is the accumulation of dust or other particles between conductors which induce tracking or electrical bridging of the insulation between conductors such as those on printed circuit boards. When protection from dust accumulation is provided by the equipment enclosure or coatings on printed circuit boards, most standards will standards will permit

a reduction in the specified conductor separation distance. Yet another reason for requiring conductor separation is the possibility of tracking and arcing with can be viewed as ignition sources. The safety related concerns in conductor separation spacings are summarized in Figure 6. I.

2. Determining Spacing Requirements.

To determine the spacing distance required for

Figure 6.1

Safety Concerns and Conductor Spacings

Conductor Situation	Circuit Response	Circuit Performance	Safety Concern
Close	Arcing	Malfunction	Ignition
Touching	Short Circuit	Malfunction	Ignition or Shock
Tracking (1)	Bridged Insulation	Malfunction	Electric Shock
Transients (2)	Stressed Insulation	Insulation Failure Risk	Ignition or Shock

- (1) The parameter associated with tracking is Comparative Tracking index, CTI. It is a measure of the tendency of an insulating material to form a conducting path between two conductors in the presence of a voltage and a weak electrolyte.
- (2) Normal transients expected from the mains supply are accounted for in the spacing requirements of standards. other transients must be accounted for by increasing the spacings given in the

conductor spacing situations, standards have tables of spacing values which have incorporated the following parameters:

1. Insulation class such as operational or basic, supplemental or reinforced.
2. Rated working voltage of the circuit.
3. Equipment insulation, Class I or Class II
4. Provision for protection from dust and pollution.
5. Insulation function such as separation of primary power conductors or insulate secondary circuits from primary power.
6. Type of conductors involved such as termination of primary power at terminals, conductors on printed circuit boards or internal wiring of motors.

The values given in the spacing, creepage and clearance tables of product safety standards are minimum conductor separations unless one or more notes with the table apply. The values for conductor spacings normally do not account for severe voltage transients, but assumes the rated working voltage plus a nominal voltage excursion common to utility mains. If a circuit is subject to surges or over voltages which are well above the rated working voltage, the designer should consider adjusting the rated working voltage upward to reflect these voltage excursions. In such situations enter the spacing tables at the adjusted working voltage rather than the nominal rated voltage.

Some tables will also list the minimum thickness of insulation required for insulation on wires or insulating tubing and sleeving to qualify for supplemental or

reinforced status. The total picture of the rationale behind the spacing of conductors is illustrated in Figure 6.2.

3. Common Spacing Errors.

Adequate separation of conductors is often overlooked in circuit design checks and design verification tests, or in the mechanical packaging of circuits. Some of the most common spacing errors and difficulties are listed below.

- * Spacings between primary and secondary leads as they exit transformer enclosures.
- * Creepage distances between primary and secondary windings on the same bobbin.
- * Spacings between conductive films or coatings on the inside surfaces of enclosures and active circuitry.
- * Rotation arc of the bare portion of conductors at terminal blocks.
- * Clearances between printed circuit board mounting hardware and active circuitry on the board.
- * Thickness of insulation or distance through insulation not enough to qualify as supplemental insulation.

One method of checking for the adequacy of spacings is to use circuit schematics on which the various circuits are traced in color. The primary circuits are traced in one color, secondary circuits traced in another color, safety circuits in a different color and earth ground circuit in still another color. The conductor types now in identifying colors can be reviewed for required spacings.

Figure 6.2

Factors Determining Conductor Spacings

Spacing

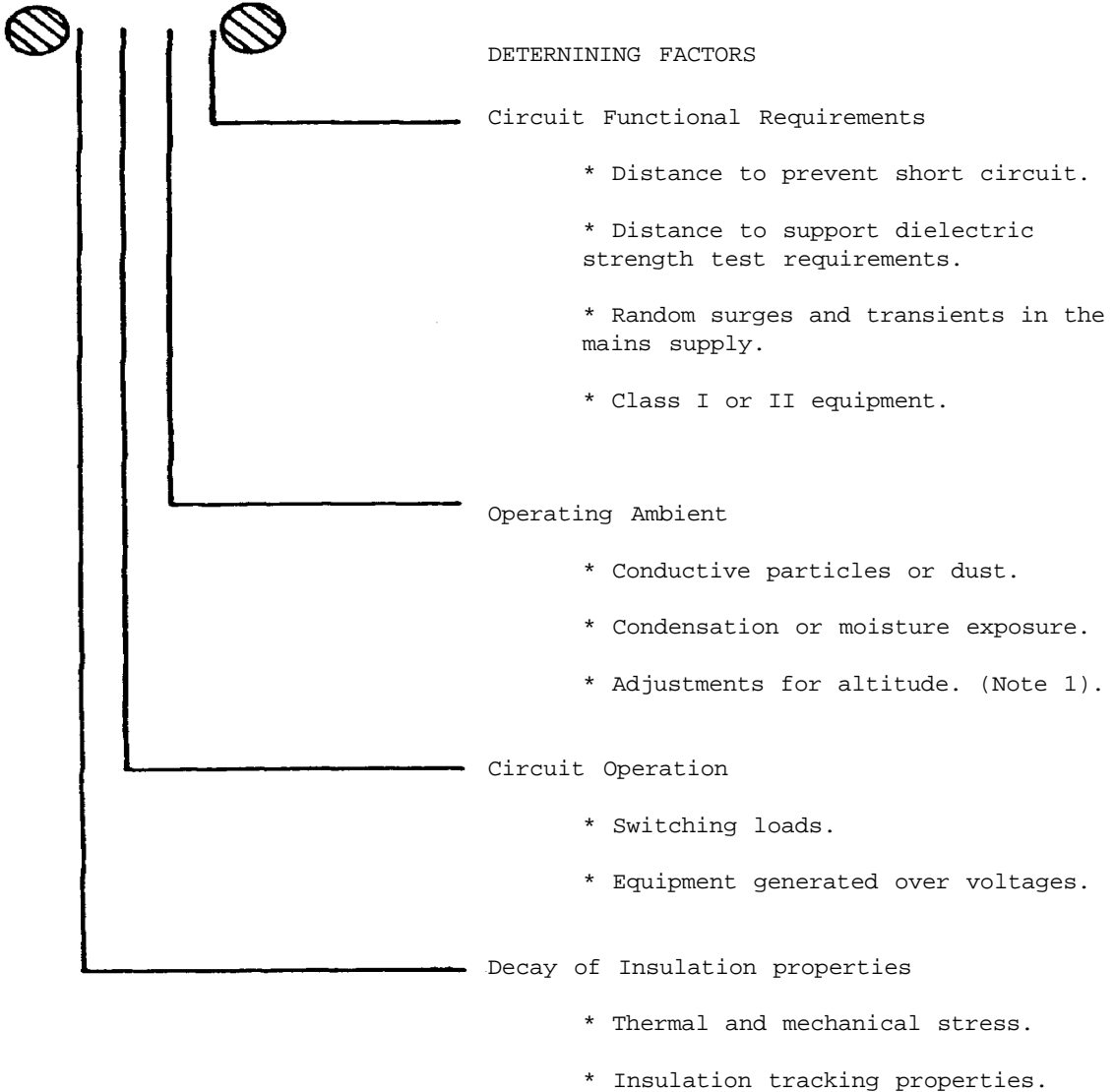

Note 1. Many standards limit spacings specified in the tables to equipment usage up to 2000 meters (6,560 feet).

A similar method can be used for printed circuit layouts using a copy of the proposed conductor routing layout. Between conductors the worst case voltage is noted and the minimum permissible spacing distance specified for use by the printed circuit board layout technician.

4. Design Approach to Conductor Spacing. The best design approach to conductor spacing is to separate conductors as generously as the enclosure volume or printed circuit board area permit. When enclosure volumes or printed circuit board areas are limited, consult the standards governing the equipment for minimum spacings permitted and investigate any exceptions the standards may permit.

Include provision for protection from the accumulation of dust so as to qualify for lower spacings if the standard has not already accounted for it. If standards permit dielectric strength testing as an alternate to physical spacing distances, consider this alternate because it will generally offer the possibility for closer positioning of conductors for a given working voltage.

Other considerations in determining appropriate spacing of conductors are given in Appendix C; Spacings, Creepage and Clearance Considerations.

Technically Speaking
Continued From page 4

ergy available to touch. But, outside the household, we have some very good examples: overhead power lines.

Overhead power lines are not enclosed. But, they are not accessible to touch because they are mounted high

on poles or towers that have no readily available means for climbing. Let's presume a means is provided such that you can climb the power pole or tower. How close are you willing to approach the bare power line? Would you be willing to approach that power line to the minimum distance such that you are not likely to touch it? Probably not.

For the moment let's presume the power line is insulated. Now, how close are you willing to approach the insulated power line? Would you be willing to touch the insulation? Probably. What is the "thing" that is interposed between you and the insulated power line that provides protection against electric shock?

Answer: Insulation.

In the case of the insulated power line, insulation is interposed between you and the power line. The insulation is providing the protection against electric shock.

But, what provides the protection against electric shock in the case of a bare power line? Clearly, if we touch the bare power line we will incur a shock. Conversely, if we do not touch the bare power line, we will not incur a shock. This implies that there is some "thing" interposed between the body part and the hazardous part that provides safety. What is this "thing"?

Answer: Insulation.

As in the case of the insulated power line, there must be insulation interposed between you and the bare power line.

What is this insulation?

Answer: Air.

Air is an electrical insulating medium. Air is the most common, reliable, and cheapest insulator in use today.

The air between you and an energized part provides the insulation that protects you against electric shock --- from any voltage.

All parts not enclosed in solid insulation are “automatically” enclosed in air insulation. The air occupies a volume surrounding the part. In the case of overhead power lines, this volume appears to extend for miles. But, the overhead lines only need some minimum volume around them to be sufficient insulation to provide protection against electric shock. We’ll discuss this later in this paper.

The problem with air as insulation is that it is a fluid. Because it is a fluid, the volume of air providing insulation can be **DISPLACED** by any solid body, including a part of the human body.

When the particular volume of air that is providing insulation is displaced by a body part the insulation is thereby removed from the hazardous part and a shock or burn can be incurred.

The function of the enclosure (or the pole or tower for power lines) is to preserve the air as an insulator. The enclosure, pole, tower, or fence (around a substation) is a barrier that prevents a body part or other foreign object from displacing the volume of air insulation that is providing the protective function.

The function of the enclosure is **NOT** to prevent access to hazardous conductors.

The function of the enclosure is to **PRESERVE** (prevent displacement of) the insulation provided by the volume of air surrounding the parts.

The conventional wisdom that preventing accessibility thereby prevents injury is a myth.

How much air is required to provide protection against electric shock?

Insulation can be modeled as a parallel circuit comprised of a capacitor, a resistor, and a spark-gap.

By definition, any two conductors separated by an insulating medium constitute a capacitor. In the case of electric shock one plate of the capacitor is the energized conductor, the other plate is the body part. (For the purposes of evaluating electric shock, the body should be thought of as a grounded conductor.)

Insulation has a finite value of resistance. Usually, it is sufficiently high that it can be ignored. As with the capacitor, one terminal of the resistor is the conductor, the other terminal is the body.

Finally, all insulations will break down if the voltage across that insulation is high enough. This is the spark-gap part of the model. As with the capacitor and resistor, one terminal of the spark gap is the conductor, the other is the body.

Insulation is not always insulation. Insulating materials have two states, one being that of an insulator, the other being that of a conductor (when the insulation breaks down). (There are some intermediate states which we will ignore in this discussion.)

While we normally can’t see air, we have all seen evidence of air in both states, as an insulator and as a conductor. Most of the time, we see evidence of air as an insulator, i.e., electrical energy remains in the conductors. When we see an arc, we see evidence of air as a conductor, i.e., electrical energy leaps from one

conductor through the air to another conductor.

The line between insulation and conduction is the electric strength of the insulation.

The performance of air as an insulator is clearly depicted in IEC 664-1. The electric strength of air is principally a function of the distance through air. The more air, the higher the electric strength of the insulation.

The worst-case line between air as an insulator and air as a conductor (breakdown) for distances between 0.1 mm up to about 1.0 mm is about 1100 volts peak per mm plus 700 volts peak.

The best-case line between air as an insulator and air as a conductor (breakdown) for distances between 0.1 mm up to about 1.0 mm is about 3400 volts peak per mm plus 700 volts peak.

Stated as formulae:

Peak breakdown voltage (worst) = $(1100)(D) + 700$

Peak breakdown voltage (best) = $(3400)(D) + 700$

where D is the distance between conductors in mm, from 0.1 to 1.0 mm.

(For those familiar with IEC 664, these formulae are for inhomogeneous and homogeneous fields. The point of this discussion is that air is an insulator. This discussion is not to discuss the specific parameters of air insulation.)

In answer to the question, how much air is required to provide protection against electric shock, at 1 mm, air will break down at

1800 volts peak or about 1200 volts rms (worst), and 4100 volts peak or about 2900 volts rms (best).

At 1 mm, air is always an insulator for all voltages

below 1200 volts rms, and always a non-insulator for all voltages greater than 2900 volts rms.

The principal means of providing protection against electric shock is the interposition of insulation between the conductor and the body.

In other words, protection against electric shock is by enclosing with solid insulation or enclosing with air insulation or a combination of both.

When using air insulation, a physical barrier such as an enclosure or other device may be employed to prohibit inadvertent displacement of the air insulation.

Working this way about air gives a powerful tool for the design of products. For example, the problem of the hair dryer falling into a bathtub is a problem of water displacing the air insulation. If a hair dryer did not use air insulation, then there would be no hazard when dropped into the bathtub.

On the other hand, if you could build a detector to detect when water displaced the air, then you could automatically disconnect the dryer from the supply voltage, thus providing protection against electric shock. Newer hair dryers use such a device.

Inaccessibility as a means of protection is a myth. "Accessibility" is nothing more than a measure of whether or not the air insulation can be displaced by a body part.

Your comments on this article are welcome. Please address *your comments to the Product Safety Newsletter*, Attention Roger Volgstadt, c/o Tandem Computers Inc., 10300 N. Tantau Avenue, Location 55-53 Cupertino, California 95014-0708.

other DIN, ISO, IEC publications.

IEEE - Electronic and the Environment

The IEEE Technical Advisory Board has announced a call for papers W the second International Symposium on Electronics and the Environment. This is scheduled for May 2A 1994 at the San Francisco Airport Marriott.

Standards New Published

MC760-1989 Amendment 1-1993, flat, quick disconnect terminals - \$30.00

Standard Revision

The *ANSI Standard Action* has published a list of UL standards that are being reviewed. Contact the UL offices for details.

UL 198B - *Class F Fuses*

UL198D - Class K Fuses

UL198F - Plug Fuses

UL796E - Printed Wiring Boards

UL 1 577 - Optical Isolators

Status on UL's new facility in Washington

The following information is reprinted with permission from the September/October, 1993 issue of *International Product Safety News*, published by Product Safety International of Middletown, CT.

UL has initiated construction on their Camas, Washington facility. It is 115,000 square feet in area and will serve clients located in the Northwestern US, Western Canada and the Pacific Rim countries. Completion is scheduled for the third quarter of 1994. At startup, UL will employ about 20 engineers plus support staff. By the end of the first year, they plan to employ 150 people.

"The Technical Committee on Product Safety is concerned with the ~~electrical~~ safety of ~~electronic~~ products. The Committee strives to advance the knowledge and awareness of product safety through: - Study of product safety engineering principles and applications, ~~including these related to EMC~~
-Promotion of consistent understanding and interpretation of applicable product safety ~~standards~~ *requirements and considerations*
~~-Understanding of the contribution to product safety of the test house~~
-Understanding of the certification process
-Review of emerging *technology and* standards
-Study of the implementation of product safety principles within organizations."

First, the changes show that there's a lot more to product safety investigation than electrical fire and shock. The Product Safety Workshop at the EMC Symposium dealt with such diverse product-related safety topics as environmental safety and human factors, which were seen by the attendees as very relevant. Second, they reflect our acknowledgment that standards, while they are very important, are essentially reflections of long-past experience and that it is important to address new technologies, changes of societal attitudes and other considerations that may take years to be reflected in standards. Third, they indicate that we have broadened our scope to be able to include any product/system that is within the scope of the IEEE.

In past issues I have shared out goal of affiliating with other societies as a Technical Council in order to provide a key focus for product-related safety within

the IEEE. As we expand into what we now perceive our scope to be, our linkages with other EEEE groups will be stronger and more natural.

Peer-Review Publications

One of the few areas where TC-8 has lagged is in the area of fostering development, publication and presentation of peer-reviewed papers. At the annual meeting, there was a consensus that we need to emphasize this activity as key to our continued growth and the furtherance of product safety practice. Part of our shyness about preparing papers may arise from the perception that most product safety practice is not as "technical" as dissertations on Maxwell's equations or sub-quarter-micron semiconductor processing. Rather than trying to poorly imitate the highly technical nature of other technical disciplines, our writing should reflect the best and newest of what product safety is; the intersection/union of products and technology, societal expectations, assumption of risk and the law. I encourage each of you to consider how you might contribute to the written body of product safety knowledge. We hope to sponsor a session of original papers at the EMC Symposium next summer in Chicago. We don't know yet whether we will receive enough quality papers to accomplish this goal before the submission deadline, but that is no excuse for anyone not beginning here and now to commit to preparing a submission for the 1995 Symposium.

I am requesting each of you to reflect and expand on this topic and respond with your thinking. I can be reached during business hours by phone at Lam Research at (510)659-6574 or by fax at (510)659- 6852. Regretfully, I'm not on E-mail yet, but feel free to use the phone or fax to share your ideas.

Can You Help?

One of our readers asks, "does anyone have a checklist of the UL478 (4th Edition) Standard? The Mexican Standards for most [data processing equipment] products is 95% equivalent to UL478, 4th Edition. The checklist might be similar to ECMA TR39 form for EN 60950"

Also, if you have any information regarding an upcoming product safety related conference or symposium, please contact the News and Notes Editor.

Institutional Listings

PAUL W. HILL & ASSOCIATES, INC.
601 S.W. 4th Street
Boca Raton, Florida 33486
(407) 368-2538

PRODUCT SAFENESS

- * Seminars for Designers & Product Developers
- * Design Reviews * Certification Assistance

**R&L
Ingenieur
Consulting
GmbH**
Approval Service
for European Safety
and rfi-approval marks

65479 Raunheim
Germany
Phone: 01149 6142 43676
Fax: 01149 6142 41721

contact:
Helmut Landeck
(VDE)

15 years experience in
product safety consulting
inhouse seminars and
prototype evaluations.



MET Laboratories, Inc.

*The First Nationally Recognized Testing Laboratory
Licensed by OSHA*

914 W. Patapsco Avenue, Baltimore, MD 21230-3432
(410) 354-3300 (800) 638-6057 FAX (410) 354-3313

NCB Laboratory for Global Certification

**MET is the test laboratory for listing, labeling
and certification that works with you, for you.**

NRTL - CSA - FCC - DOC

EASI SOLUTIONS - UL 1950

EASI

Expert Application Systems, Inc.
8920 Business Park Drive, Suite 377
Austin, TX 78759
(512) 338-9773 (512) 794-9997 (FAX)

**CALL TODAY FOR YOUR FREE DEMO DISK OF
EASI SOLUTIONS - UL 1950**

SOFTWARE FOR STANDARDS

Accessibility & Safety Test Probes

precision made in the U.S.

by



Most complete selection of probes
to meet IEC, ISO9000, UL and industry standards
Examples: articulated finger, telecom probes, coin and jewelry probes
Available in kits or individually

**For brochure: call 215-357-5124 or fax 215-364-7582
Address: Box 964, Southampton, PA 18966**

NEMKO

- * Testing, certification and inspection.
- * NORDIC, CB certificates and ISO 9000 assessment.
- * US office established with engineering services.

For more information, contact NEMKO at:

NEMKO Product Safety, Inc.
2131 Palomar Airport Road,
Suite 300, Carlsbad, CA 92009
Phone: (619) 431-5131,
Fax: (619) 431-2449

NEMKO
Gaustadalleen 30, Blindern
0314 Oslo, Norway
Phone: +4722-960-330
Fax: +4722-698-636



Inchcape Testing Services

DAWNA M. URLAKIS
REGIONAL SALES MANAGER

ETL Testing Laboratories, Inc.

260 East Grand Ave. #38 • South San Francisco, CA 94080 • Telephone 415-871-1414
FAX 415-873-7357



**FOR LOCATING
Energized Circuits, Defective
Grounds & Induced Voltage
SANTRONICS AC SENSOR**
Part # 3115

- 100% American Made
- UL Listed

See Your Safety Products Distributor

SANTRONICS, INC.
P.O. Box 192, Sanford, NC 27331-0192

We are grateful for the assistance given by these firms and invite application for Institutional Listings from other firms interested in the product safety field. An Institutional Listing recognizes contributions to support publication of the Product Safety Newsletter of the IEEE EMC Society Product Safety Technical Committee. Please direct inquiries to:

Ron Baugh at 503-691-7369 (phone) or 503-691-7568 (fax).

CERTELECOM LABORATORIES INC.

THE DOORWAY TO GLOBAL APPROVAL

USA 820 PROCTOR AVENUE
OGDENSBURG, NEW YORK 13669
TELEPHONE: (315) 393-6546
1-800-348-9433
FACSIMILE: (315) 393-7859

CANADA 3325 RIVER ROAD, R.R. No. 5
OTTAWA, ONTARIO K1G 3N3
TELEPHONE: (613) 737-9680
1-800-563-6336
FACSIMILE: (613) 737-9691

INTERNATIONAL COMPLIANCE AND PERFORMANCE TESTING OF ELECTRONIC PRODUCTS-- FCC, DOC, VDE, JATE, AUSTEL, UL, CSA, TUV, IEC, VCCI, CISPR, ANSI/IEEE

AUSTEL ACCEPTS CERTELECOM ELECTRICAL SAFETY CERTIFICATION WITHOUT WITNESS TESTING.

NVLAP ACCREDITATION

Everything you need for Product Safety!

Product Safety Test Equipment

Leakage Current Meters-Accessibility Probes-Ground Continuity Testers-Force Gauges-Impact Balls-Feeler Gauges-Ball Pressure Testers-Thermocouples-Thermocouple Paste & Much More.

Product Safety Evaluation Services

Consulting Services - Seminars - Personalized Training - Training Materials - Design Services

Educated Design & Dev., Inc.

2015 Progress Court, Raleigh, N.C. 27608
Phone (919) 821-7088 Fax (919) 821-1939

**Your One Stop
Product Safety
Shop™**



Take a UL Seminar

Learn how to specify plastic materials that reduce testing costs and speed products to market.

Plastics in Electronic and Electrical Products

Oct. 27-28, 1993

Hyatt Regency Woodfield, Schaumburg, Ill.

For more information, call Underwriters Laboratories Inc.
Phone: (708) 272-8800, Ext. 43481 Fax: (708) 272-0919



Safety Engineering Laboratory

- UL, CSA and TÜV for worldwide compliance
- Over 24 years experience in product safety
- 3 in 1 checklist for UL1950/CSA950/EN60950
- Provide our own test equipment at your factory
- Our role decreases as we train your in-house people

18100 Constitution Avenue Monte Sereno, CA 95030
(408) 354-8007 Fax (408) 354-1044



211 Schoolhouse Street
Coquitlam, B.C. CANADA
V3K 4X9
Telephone (604) 520-3321
Fax (604) 524-9186

Products Tested to CSA
Standards Don't Have to Say

” CSA ”

Next Time Call

WARNOCK HERSEY

Accredited by the Standards Council of Canada to
Certify to CSA Standards.

Complete Electrical/Electronic
CERTIFICATION and TESTING SERVICE



Inchcape Testing Services

North American and International Testing and Consulting
Product Safety • OSHA-NRTL • CE Marking • CB Scheme
European Notified Body • EMC/LVD/MDD/GAD/MSD Directives

27 Locations Worldwide
Call 1-800-WORLDBL
Fax toll-free: 1-800-813-9442

**WORLDWIDE TELECOMMUNICATION
DESIGN SERVICES & TYPE APPROVALS**



PATTON & ASSOCIATES, INC.

1600 W. Manzanita Dr., Prescott, AZ 86303-6121
Tel: 520.771.2900 Fax: 520.771.2990
Internet: 76600.2524 @ compuserve.com

The
Product
Safety
Newsletter

c/o Tandem Computers Incorporated
10300 North Tantau Avenue, Loc 55-53
Cupertino, CA 95014
Attn: Roger Volgstadt

BULK RATE
U.S. POSTAGE PAID
CUPERTINO, CA
PERMIT NO. 138

ADDRESS CORRECTION REQUESTED

Employment Wanted

Bogdan M. Matoga
Hollister, CA
(408) 636 8182

Mariano Fe de Leon
Gilroy, CA
(408) 848 3851